

# Installation and Maintenance Manual

eVALV

TWO-PORT CONTROL VALVES



## Table of Contents

1.	Preface .....	1
2.	Safety Information.....	1
3.	General Product Information.....	4
4.	Working Principal .....	5
5.	Installation and Commissioning.....	6
6.	Maintenance Guidelines DN15 - DN100.....	7
7.	Spares Parts (valve).....	13
8.	Installation of Actuator.....	15
9.	Maintenance of Actuator.....	16
10.	Spare parts (Actuator).....	21
11.	Warranty Period.....	28

**PLEASE NOTE** - Throughout this manual this cautionary symbol is used to describe a potential damage or injury that might occur if the safety considerations are overlooked. This symbol denotes CAUTION, WARNING or DANGER.



## 1. Preface:

This manual is intended for anyone using, commissioning, servicing, or disposing the below mentioned products safely and efficiently.

### eVALV

Size: DN 15 (½"), DN 25 (1"), DN 40 (1 ½"), DN 50 (2"), DN 80 (3") and DN 100 (4")

Actuator: FM Actuator A0, A1 & A2

### PLEASE NOTE:

Throughout this manual the following cautionary symbol is used to describe a potential damage or injury that might occur if the safety considerations are overlooked.

## 2. Safety Information:



In current scenario, every industry requires safe operation of products. Safe operation of these products can only be guaranteed if they are properly installed, commissioned, used and maintained by qualified personnel (see Section 2.10) in compliance with the operating instructions. General installation and safety instructions for pipeline and plant construction, as well as the proper use of tools and safety equipment must also be complied with.

### 2.1 Intended use:

Referring to the Installation and Maintenance Instructions, name-plate and Technical Information Sheet, check that the product is suitable for the intended use / application. The products have been specifically designed for use with steam which are in Groups 1 and 2 of the above mentioned Pressure Equipment Directive. Check material suitability, pressure and temperature and their maximum and minimum values. If the maximum operating limits of the product are lower than those of the system in which it is being fitted, or if malfunction of the product could result in a dangerous overpressure or over temperature occurrence, ensure a safety device is included in the system to prevent such over-limit situations. Determine the correct installation situation and direction of fluid flow.

System to which they are fitted. It is the responsibility of the installer to consider these stresses and take adequate precautions to minimize them. Remove protection covers from all connections and protective film from all name-plates, where appropriate, before installation on steam or other high temperature applications.

### 2.2 Access:

Ensure safe access and if necessary a safe working platform (suitably guarded) before attempting to work on the product. Arrange suitable lifting gear if required..

### 2.3 Lighting:

Ensure adequate lighting, particularly where detailed or intricate work is required.

## **2.4 Hazardous liquids or gases in the pipeline and hazardous environment around the product.**

Consider: what is in the pipeline or what may have been in the pipeline at some previous time.

Consider: flammable materials, substances hazardous to health, extremes of temperature. Hazardous environment around the product.

Consider: explosion risk areas, lack of oxygen (e.g. tanks, pits, columns), dangerous gases, extremes of temperature, hot surfaces, fire hazard (e.g. during welding), excessive noise, moving machinery.

## **2.5 The system:**

Consider the effect on the complete system of the work proposed. Will any proposed action (e.g. closing isolation valves, electrical isolation) put any other part of the system or any personnel at the risk?

Dangers might include isolation of vents or protective devices or the rendering ineffective of controls or alarms. Ensure isolation valves are turned on and off in a gradual way to avoid system shocks..

## **2.6 Pressure systems:**

Ensure that any pressure is isolated and safely vented to atmospheric pressure. Consider double isolation (double block and bleed) and the locking or labelling of closed valves. Do not assume that the system has depressurized even when the pressure gauge indicates zero.

## **2.7 Temperature:**

Allow time for temperature to normalize after isolation to avoid the danger of burns and consider whether protective clothing (including safety glasses) is required.

## **PTFE SEALS**

If seals made from PTFE have been subjected to a temperature approaching 260°C (500°F) or higher, they will give off toxic fumes, which if inhaled are likely to cause temporary discomfort. It is essential for a no smoking rule to be enforced in all areas where PTFE is stored, handled or processed as persons inhaling the fumes from burning tobacco contaminated with PTFE particles can develop 'polymer fume fever'.

## **2.8 Tools and consumables:**

Before starting work ensure that you have suitable tools and / or consumables available. Use only genuine Forbes Marshall replacement parts.

## **2.9 Protective clothing:**

Consider whether you and / or others in the vicinity require any protective clothing to protect against the hazards of, for example, chemicals, high / low temperature, radiation, noise, falling objects, and dangers to eyes and face.

### **2.10 Permits to work:**

All work must be carried out or be supervised by a suitably competent person. Installation and operating personnel should be trained in the correct use of the product according to the Installation and Maintenance Instructions.

Where a formal 'permit to work' system is in force it must be complied with. Where there is no such system, it is recommended that a responsible person should know what work is going on and, where necessary, arrange to have an assistant whose primary responsibility is safety. Post 'warning notices' if necessary.

### **2.11 Handling:**

Manual handling of large and /or heavy products may present a risk of injury. Lifting, pushing, pulling, carrying or supporting a load by bodily force can cause injury particularly to the back. You are advised to assess the risks taking into account the task, the individual, the load and the working environment and use the appropriate handling method depending on the circumstances of the work being done.

### **2.12 Residual hazards:**

In normal use the external surface of the product may be very hot. If used at the maximum permitted operating conditions the surface temperature of some products may reach temperatures of 538°C (1000°F).

Many products are not self-draining. Take due care when dismantling or removing the product from an installation (refer to 'Maintenance instructions')

### **2.13 Freezing:**

Provision must be made to protect products which are not self-draining against frost damage in environments where they may be exposed to temperatures below freezing point.

### **2.14 Disposal:**

Unless otherwise stated in the Installation and Maintenance Instructions, this product is recyclable and no ecological hazard is anticipated with its disposal providing due care is taken. However, if the valve is fitted with a Viton or PTFE seat, special care must be taken to avoid potential health hazards associated with decomposition / burning of these seats.

#### **PTFE:**

Can only be disposed of by approved methods, not incineration.

Keep PTFE waste in a separate container, do not mix it with other rubbish, and consign it to a landfill site.

### 2.15 Returning products:

Customers and stockiest are reminded that under EC Health, Safety and Environment Law, when returning products to Forbes Marshall they must provide information on any hazards and the precautions to be taken due to contamination residues or mechanical damage which may present a health, safety or environmental risk. This information must be provided in writing including Health and Safety data sheets relating to any substances identified as hazardous or potentially hazardous..

### 3. General Product Information :

eVALV is a range of two-port single seat globe valves with cage-retained seats. These valves are available as follows:

DN15 to DN100 (½" to 4") with body material SG iron with class150 and WCB with class 300

eVALV two-port control valves are compatible with the following actuators and positioners

Table 1	
<b>Pneumatic Actuator :</b>	Pneumatic, diaphragm actuator
<b>Positioners :</b>	Electro-pneumatic
<b>eVALV :</b>	Equal percentage (E) - Suitable for most modulating process control applications providing good control at low flow-rates.

### Pressure / Temperature limits

#### eVALV (SG iron valve body)

Table 2	
<b>Body design conditions :</b>	<b>Class 150</b>
<b>Maximum operating pressure :</b>	17 bar g (Screwed) 13 bar g (Flanged)
<b>Maximum operating temperature :</b>	232°C @ 17 bar g
<b>Minimum design temperature (Standard packing)</b>	-10°C
<b>Maximum differential pressures (See relevant actuator Technical Information sheet.)</b>	
<b>Maximum cold hydraulic test pressure:</b>	26 bar g

**4. Working Principle :**

4-20 mA current supply is required to positioner. Controller gives current supply to the positioner as per the of process requirement

As per the current supply given to the positioner, it converts that into pneumatic pressure response to the actuator

Pneumatic pressure compresses the spring in the actuator and then actuator stem goes up or down depending on the orientation of the valve (Normally close or normally open)

As actuator stem is coupled with valve stem, it gives actuation to the valve stem also. Valve opens and opens and closes as per the current response to positioner from controller.

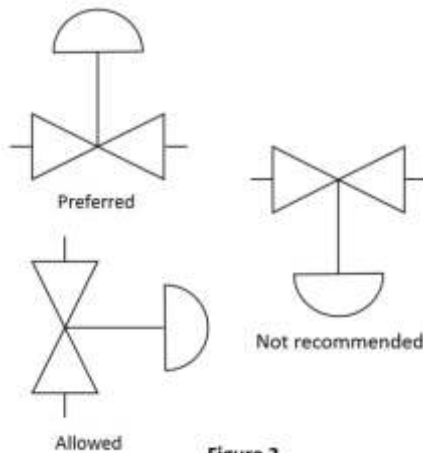

**Figure 1**

## 5. Installation and Commissioning:

**5.1** Check materials, pressure and temperature and their maximum values. Do not exceed the performance rating of the valve. If the maximum operating limit of the product is lower than that of the system in which it is being fitted, ensure that a safety device is included in the system to prevent over-pressurization.

**5.2** Remove protection covers from all connections and protective film from all name-plates, where high temperature applications.



**5.3** Determine the correct installation situation and the direction of fluid flow. The valve should preferably be installed along a horizontal pipeline with the valve mounted above the pipe (see Fig 2). When mounting an actuator to the valve body, the actuator Installation and Maintenance Instructions must be followed.

**5.4** Bypass arrangements - It is recommended that isolating valves be fitted upstream and downstream of the control valve, together with a manual bypass control valve. This enables the process to be controlled manually using the bypass valve while the pneumatic valve is isolated for maintenance (see Figure 3)

**5.5** Support pipework should be used to prevent stresses being exerted on the valve body.

**5.6** Ensure adequate space is provided for the removal of the actuator from the valve body for maintenance purposes

**5.7** Isolate connecting pipework. Ensure it is clean from dirt, scale etc. Any debris entering the valve may damage the head seal preventing the specified shut off.

**5.8** Open isolation valves slowly, until normal operating conditions are achieved.



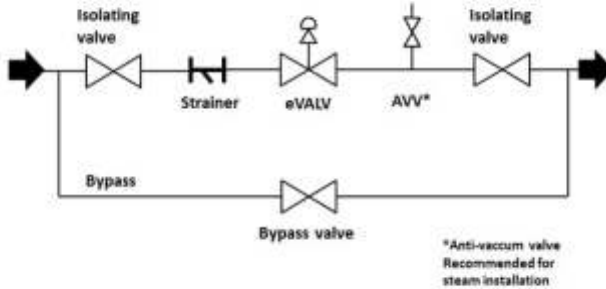

**Figure 3**

**6. Maintenance:**

Note: Before initiating any installation, observe the 'Safety information' in Section 2.

If the application permits, it is recommended that a thin layer of a PTFE based grease is applied to any mating parts before reassembly.

**General::**

Valve parts are subject to normal wear and must be inspected and replaced as necessary. Inspection and maintenance frequency depends on the severity of the service conditions. This section provides instructions on replacement packing, stem, plug and seat. All maintenance operations can be performed with the valve body in the line.

**Annually:**

The valve should be inspected for wear and tear replacing any worn or damaged parts such as valve plug and stem, valve seat and gland seals, refer to Section 7 'Spare parts'.

**Recommended tightening torques for Body**

**Bonnet Joint Hex Bolts (Reference Figure 4)**

**Table 3 –Size wise tightening torques**

eVALV Size	Torque (Nm) for #150	Torque (Nm) for #300
DN15 - DN25	70	70
DN40 - DN50	90	90
DN80	110	130
DN100	110	130

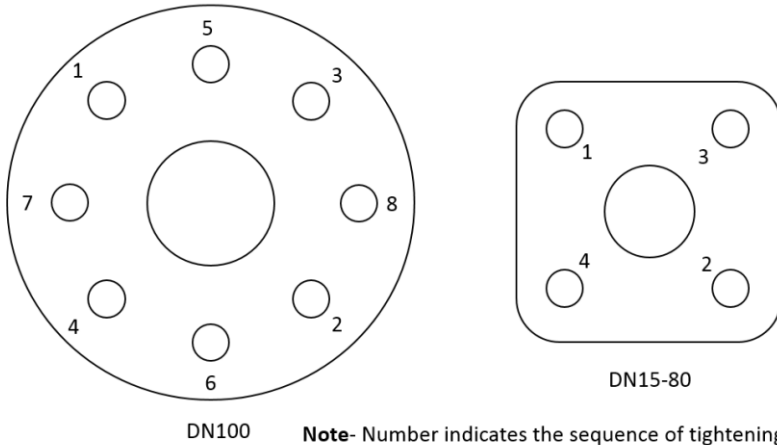

**Figure 4**

**Note- Gland nut tightening torque 20 Nm**

### 6.1 Removal of valve bonnet

**(Reference Figure 5a, 5b & 6)**

Note: This procedure is necessary before carrying out any of the maintenance procedures detailed below:

- Ensure that the valve is depressurized and clear of media and isolate it both upstream and downstream.
- **Caution:** Care should be taken when disassembling the valve in case of residual pressure being trapped between the isolation points.
- First depressurize the actuator, disengage pin at feedback link and c link of positioner then disengage actuator stem from valve stem by removal of Allen bolts of coupling.
- Then apply air pressure to actuator, dismantle coupling halves then remove slotted nut from valve bonnet.
- Undo and remove the bonnet bolts (19).
- Remove the bonnet (2) and plug and stem assembly (5).
- Remove and discard the body gasket (9).

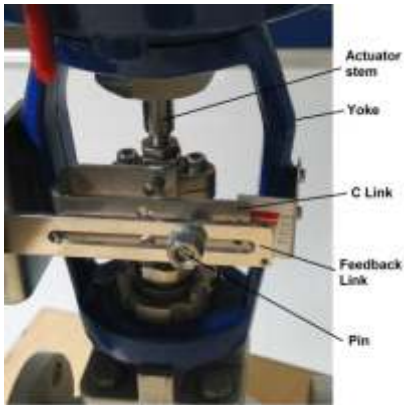

Figure 5a

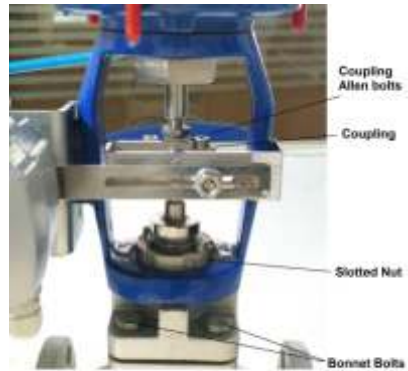
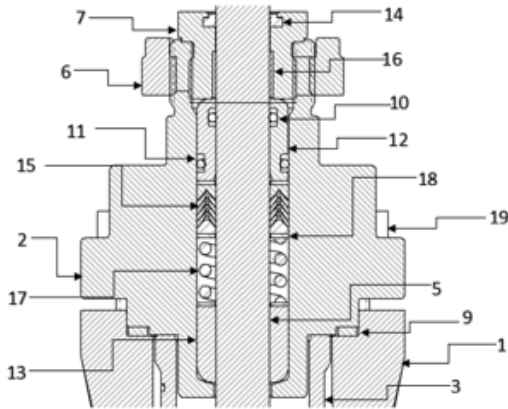

Figure 5b

## 6.2 Removal and replacement of PTFE gland packings

### (Reference Figure 6)

- Take plug and stem assembly out from bonnet bore.
- Remove the gland nut (7), take out gland bush (12) from bonnet bore. Remove Scrapper ring (14) and sliding bearing (16) from gland nut. Remove 'O' rings (10 and 11) from the gland bush, ensuring that the grooves are clean and undamaged, and replace with new items. The use of silicone grease on the 'O' rings is recommended. .
- Withdraw the gland components and discard (10, 11 12, 15 &13).
- Clean the gland cavity bore and fit new gland components in the order as shown. Note that the guide bush must be fitted with the edge having radius downwards. When fitting the chevron seals they should be inserted with downward V orientation as indicated in figure 5, one at a time to ease the assembly process.
- Prior and after insertion of spring (17) in the bore put washers (18)
- Apply a thin layer of anti-seize lubricant to the gland nut threads before screwing it in two or three turns. At this stage the packing must not be significantly compressed.



**Figure 6**

### 6.3 Removal and replacement of Graphite gland packings :

#### (Reference Figure 7)

- Take plug and stem assembly out from bonnet bore.
- Remove the gland nut (5), take out gland bush (6) from bonnet bore. Remove Scrapper ring (14) from gland nut and discard. Ensure that the gland bush is clean and undamaged otherwise replace with new one. The use of silicone grease on internal surface of gland bush is recommended.
- Withdraw the gland components and discard (7, 8 & 10)

Use some soft hand tool from lower side of Bonnet to push entire packing set out of the bonnet (as shown)

- Clean the gland cavity bore and fit new gland components in the order as shown. Note that the guide bush must be fitted with the edge having groove downwards. When fitting the Graphite rings they should be inserted with Top & Bottom braided & middle all moulded rings as indicated in figure 7, one at a time to ease the assembly process.
- Apply recommended grease to all spindle OD (4), Gland Bush ID(6), spacer ID (9) before assembly
- Apply a thin layer of anti-seize lubricant to the gland nut threads before screwing it in two or three turns. At this stage the packing must not be fully compressed.

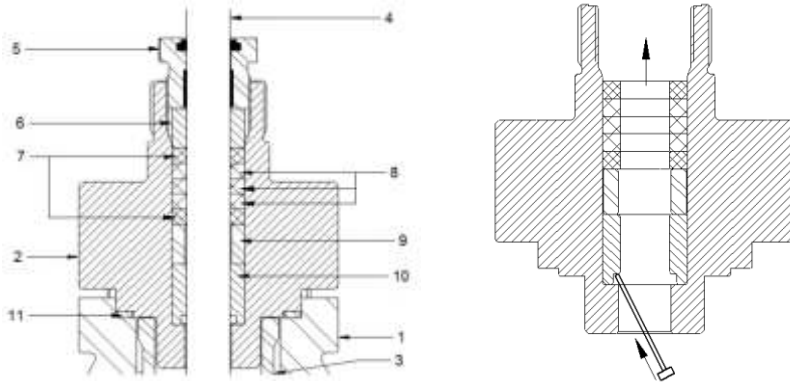

**Fig.7**

#### **6.4 Removal and refitting of the valve plug /stem assembly and seat :**

**(Reference Figure 8)**

- Take plug and stem assembly out from bonnet bore.
- Remove the gland nut (7), take out gland bush (12) from bonnet bore. Remove Scrapping ring (14) and sliding bearing (16) from gland nut. Remove 'O' rings (10 and 11) from the gland bush, ensuring that the grooves are clean and undamaged, and replace with new items. The use of silicone grease on the 'O' rings is recommended.
- Withdraw the gland components and discard (10, 11, 12, 15 & 13).
- Clean the gland cavity bore and fit new gland components in the order as shown. Note that the guide bush must be fitted with the edge having radius downwards. When fitting the chevron seals they should be inserted with downward V orientation as indicated in figure 5, one at a time to ease the assembly process.
- Remove the bolts from bonnet by applying specified torque; take out body top gasket from groove and discard
- Lift out the seat retaining cage (3) followed by the seat (4).
- Remove the seat gasket (8) and discard.
- Clean all components, including the seat recess in the valve body.
- Examine the seat and plug / stem assembly for damage or deterioration and renew as necessary.
- While putting seat at the recess ensure that stepped part having serrations should go downward

Note: Score marks or scaly deposits on the valve stem will lead to early failure of the gland seals and damage to seat and plug sealing faces will result in leakage rates higher than those specified for the valve.

- Fit a new seat gasket (8) in the body seat recess followed by the seat (4).
- Ensure that gasket touching surfaces should be serrated.
- Refit the cage (3) ensuring that the low thickness edge is lower most and that it sits squarely on the seat without impinging on the valve body.

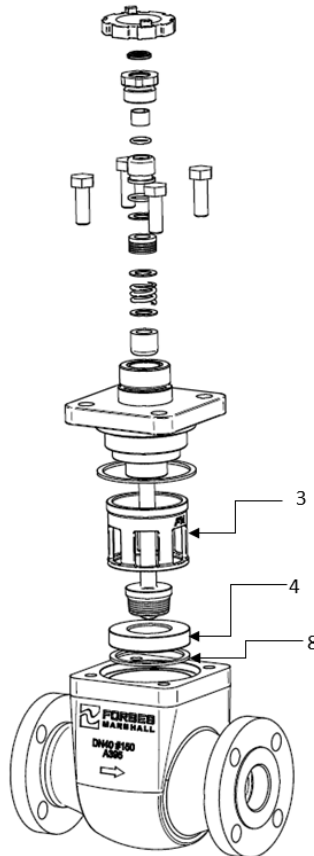

**Fig. 8**

**7. Spare parts (Valve):**

eVALV DN15 to DN100 - ½" to 4"

The spare parts available are shown in solid outline. Parts drawn in broken line are not supplied as spares.

Note: When placing an order for spare parts please specify clearly the full product description as found on the label of the valve body, as this will ensure that the correct spare parts are supplied.

**Table 4 Available spares (Reference Figure 9)**

	Class 150	Class 300
Actuator clamping nut	A	A
Gasket set	D,F	D,F
Stem seal kits	B (PTFE chevrons)	B (Graphite rings)
Plug stem and seat (No gaskets supplied)	C,E	C,E
Stem packing and gasket	F,D,B	F,D,B

**How to order spares :**

Always order spares by using the description given in the column headed 'Available spares', and state the size and type of valve including the full product description of the product.

Example: Actuator clamping nut A for Forbes Marshall Control Valve 050EVALV-Q1EGS412MI6-HWNSNN two port control valve.

**How to fit spares :**

Full fitting instructions are given in the Installation and Maintenance Instructions supplied with the spare.

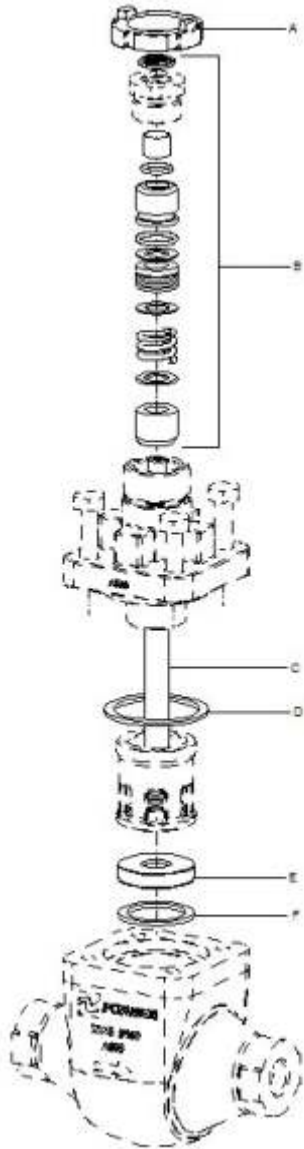

**Class150 Spares**

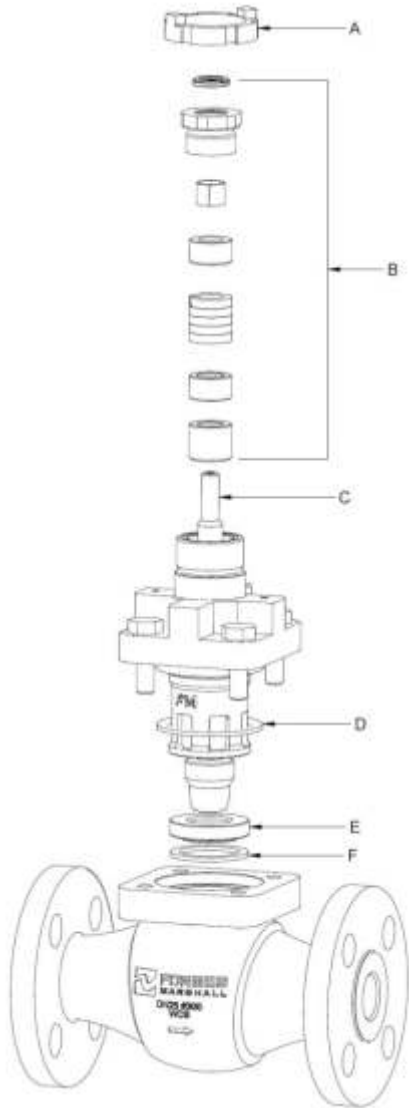

**Class300 Spares**



## 8. Installing the Actuator:

The actuators should be installed in such a position as to allow full access to both actuator and valve for maintenance purposes. The preferred mounting position is with the actuator and valve spindle in the vertical position above or below the horizontal pipework. The air supply to the actuator must be 'dry and free from oil'. For high temperature conditions, insulate the control valve and pipework to protect the actuator.

Warning: The actuator housing must only be pressurized on the opposite side of the diaphragm holding the springs. The housing vent cap must be left unrestricted.

### Fitting the actuator to a valve (Fig. 10)

- Remove both the Allen screws. Then remove the valve coupling
- Fit the valve coupling onto the valve spindle then manually push the valve plug to its closed position. Caution: Two female threads must be visible inside the coupling when fitted to the valve spindle.
- Apply the control signal pressure required to bring the spindle to mid-travel position (Figure 5). Place the actuator yoke over the valve spindle and locate it onto the bonnet shoulder. Hand tighten the slotted nut.
- Apply the minimum signal pressure + 0.1 bar maximum to the bottom of the actuator, and then adjust actuator coupling so that it touches the valve coupling, then tighten the lock-nut.
- Release the control air signal. Fit the Allen screws as shown in Figure 5.
- Operate the actuator and valve over its full travel four times to ensure alignment.
- Tighten the slotted nut to the recommended torque.

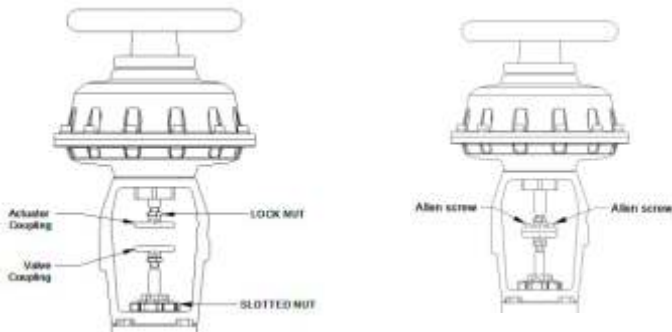

**Warning:** To prevent damage to the valve seat, please ensure the plug does not turn while pressing on the seat during assembling or adjustment. To prevent damage to the diaphragm, ensure the actuator spindle is not allowed to rotate when the diaphragm is assembled within its housing.

## 9. Maintenance:

The FM pneumatic actuators (and variants) are maintenance free. To ensure satisfactory operation it is strongly recommended that the control signal air is filtered and supplied dry and free of oil. Should it be necessary to replace spare parts the following procedure should be used.

**CAUTION! The diaphragm housing contains powerful springs under compression. Exercise great care when dismantling. Read this Maintenance section thoroughly prior to commencing any work.**

### 9.1 Removing the actuator from the valve: (Refer Fig. 10)

- Drive the actuator into approximately 25% open travel position with the air supply.
- Loosen and remove the lock nuts and Allen screws and remove the valve coupling
- Loosen and remove the slotted nut (see Figure 10) and lift the actuator off the valve.
- Reduce the air supply pressure until the housing is pressure free. Disconnect the air supply from the actuator.

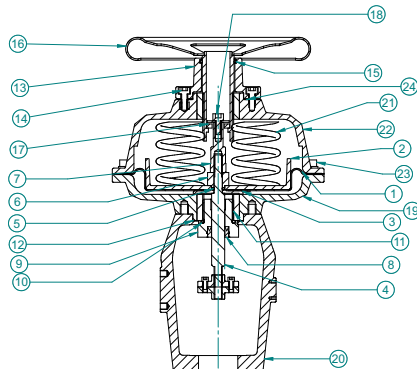

### 9.2 Normally Closed Valve:

#### A) Diaphragm kit - How to fit: (Refer Fig. 11)

- Remove the actuator from the valve as described above section 9.1

Note 1: There are 3 off longer housing Allen screws with red cap which are fitted to safely allow spring decompression. These should be removed last after all other screws are removed and should be loosened evenly to prevent distortion of the housing.

- Lubricate the threads of the three long Allen screws (20) with a PTFE based grease before releasing the tension in the springs.
- Loosen and remove the short housing Allen screws and nuts (22)

- Holding each nut with a spanner, rotate the three long Allen screws a few turns at a time. Remove the screws and upper housing (18).
- Remove the springs (17). Using a spanner to hold the actuator spindle (4), loosen the upper stem (7). Remove spring washer, Remove bush (6), 'O' ring (5), piston (2) and finally the diaphragm (1)
- Refit the new diaphragm (1) and reassemble all items in reverse order, taking care not to damage the 'O' ring. Using two spanners, while holding the actuator spindle (4) tighten the upper stem (7)
- Refit the upper housing (18) and securing the nuts and Allen screws.

**Note:** Supporting the actuator spindle (4) ensures that the diaphragm sits evenly in the lower housing. Tighten the housing screws evenly to avoid distortion. 3 off longer housing screws should be positioned 120° apart and tightened evenly prior to fitting the remaining screws To avoid distortion of the diaphragm do not fully tighten housing screws until all screws have been fitted. Final tightening should then be carried out.

Actuator Series	Screw Size	Torque (Nm)
A0	M6	30
A1	M8	40
A2	M10	50

Tightening sequence of Actuator Housing Bolts / Buts

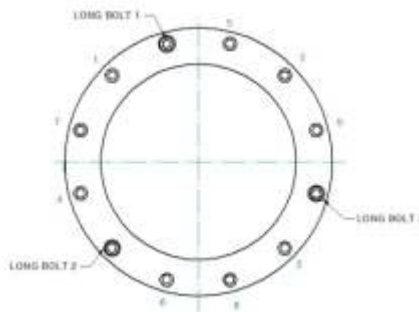

### B) Spring kit - How to fit (Refer Fig. 11)

- Remove the actuator from the valve as described in Section above 9.1
- Lubricate the threads of the three long Allen screws with a PTFE based grease before releasing the tension in the springs
- Loosen and remove the short housing Allen screws and nuts (23)

- Holding each nut with a spanner, rotate the three long Allen screws a few turns at a time. Remove the screws and upper housing (22).
- Replace with new springs. While supporting the actuator spindle (4) so that the diaphragm sits evenly in the lower housing, refit the upper housing (22) and tighten the screws evenly.

Please observe Note, above section 9.2 (A)

### C) WDB Seal holder - How to fit (Refer Fig. 11)

- Remove the actuator from the valve as described in Section above 9.1
- Remove the actuator coupling & lock nut from Actuator spindle (4)
- with the help of spanner remove the WCB seal holder (9) from the lower housing (14)
- Refit the new WDB seal holder (9) dully fitted with new WDB seal (8) , DU bearing (11) & O-ring (10)

Note- To change the WDB seal holder, no need to open Actuator Housing

### 9.3 Normally Open Valve

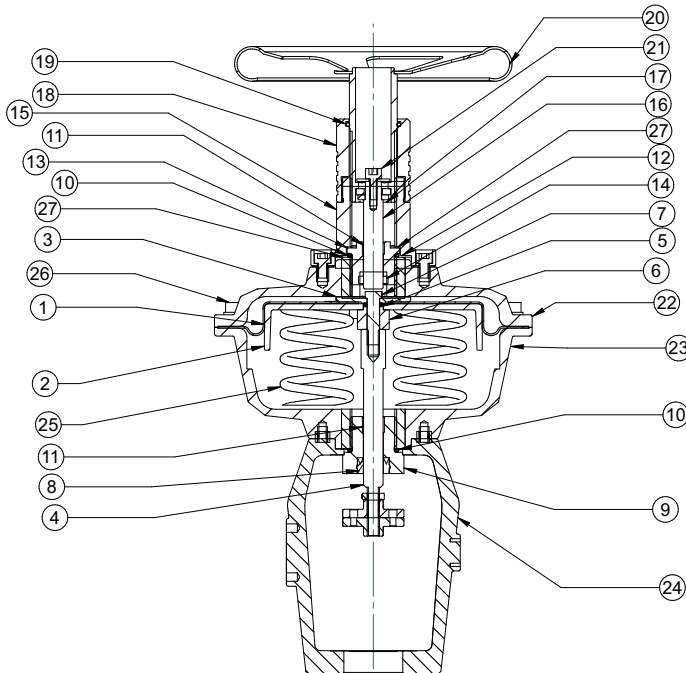

### **A) Diaphragm kit - How to fit: (Refer Fig. 12)**

- Remove the actuator from the valve as described above section 9.1
- Note 1: There are 3 off longer housing Allen screws (20) with red cap which are fitted to safely allow spring decompression. These should be removed last after all other screws are removed and should be loosened evenly to prevent distortion of the housing.
- Lubricate the threads of the three long Allen screws (20) with a PTFE based grease before releasing the tension in the springs.
- Loosen and remove the short housing Allen screws and nuts (22)
- Holding each nut with a spanner, rotate the three long Allen screws a few turns at a time. Remove the screws and upper housing (14).
- Using a spanner to hold the actuator spindle (7), loosen and withdraw the hex bolt (3)
- Taking care not to damage the 'O' ring (5) fitted between piston (2) and supporting spacer (4), remove the diaphragm (1)
- Refit the new diaphragm (1) and reassemble all items in reverse order, taking care not to damage the 'O' ring. Using two spanners, while holding the actuator spindle (7) tighten the hex bolt (3)
- Refit the upper housing (14) and securing the nuts and Allen screws.

Note – refer the Note of Section 9.2 (A)

### **B) Spring kit - How to fit (Refer Fig. 12)**

- Remove the actuator from the valve as described in Section above 9.1
- Lubricate the threads of the three long Allen screws (20) with a PTFE based grease before releasing the tension in the springs
- Refer Note of section 9.3 (A)
- Loosen and remove the short housing Allen screws and nuts (22)
- Holding each nut with a spanner, rotate the three long Allen screws a few turns at a time. Remove the screws and upper housing (14).
- Using a spanner to hold the actuator spindle (7), loosen and withdraw the hex bolt (3)
- Taking care not to damage the 'O' ring (5) remove the supporting spacer (4), diaphragm (1) and piston (2). Remove the springs (17) taking note of their location.
- Replace the new springs (17) locating them in the same position as the previous set.
- Refit all items in reverse order, taking care not to damage the 'O' ring. Using a spanner, to hold the actuator spindle (7) so that the diaphragm sits evenly in the lower housing (18), refit the upper housing (14) and securing nuts and screws (22 & 20)

Note – refer the Note of Section 9.2 (A)

### **C) WDB Seal holder - How to fit (Refer Fig. 12)**

- Remove the actuator from the valve as described in Section above 9.1
- Remove the actuator coupling & lock nut from Actuator spindle (7)
- with the help of spanner remove the WCB seal holder (9) from the lower housing (18)
- Refit the new WDB seal holder (9) dully fitted with new WDB seal (8) , DU bearing (11) & O-ring (10)

Note- To change the WDB seal holder, no need to open Actuator Housing

### **9.4 Conversion of NC to NO Actuator (Refer Figure 11 & 12)**

- Remove the actuator from the valve as described in Section above 9.1
- Remove the actuator coupling & lock nut from Actuator spindle (4)
- with the help of spanner remove the WCB seal holder (9) from the lower housing (14)
- Yoke (16) is fitted to Lower housing with the help of 2 grub screws, remove those grub screws & remove the yoke (16) from actuator.

Note 1: There are 3 off longer housing Allen screws with red cap which are fitted to safely allow spring decompression. These should be removed last after all other screws are removed and should be loosened evenly to prevent distortion of the housing.

- Lubricate the threads of the three long Allen screws (20) with a PTFE based grease before releasing the tension in the springs.
- Loosen and remove the short housing Allen screws and nuts (22)
- Holding each nut with a spanner, rotate the three long Allen screws a few turns at a time. Remove the screws and upper housing (18).
- Remove the springs (17). Using a spanner to hold the actuator spindle (4), loosen the upper stem (7). Remove spring washer, Remove bush (6), 'O' ring (5), piston (2) and finally the diaphragm (1)

Note: Use of New Diaphragm (1) is required as the same diaphragm is not recommended to use for conversion. New spindle (No) (7) & Hex bolt (3) is required for diaphragm assembly.

- Making the diaphragm sub assembly- Hold the spindle (NO) (7) in in soft vice. Put the diaphragm (1) over the piston (2) while supporting spacer (4) along with O-ring (5) on the other side of piston. Put this subassembly together over the spindle (4) in inverted position. (Note- all 4 should be holding together by hand) Insert the hex bolt (3) in the center & tighten it against the spindle threads.
- Replace the springs in same order as removed but in lower housing this time.

- Refit the diaphragm sub assembly over the lower housing
  - Place the upper housing taking care not to damage the 'O' ring. Using a spanner, to hold the actuator spindle (7) so that the diaphragm sits evenly in the lower housing (18), refit the upper housing (14) and securing nuts and screws (22 & 20)
- Note – refer the Note of Section 9.2 (A)
- Refit the Yoke on upper housing with 2 grub screws & then WDB seal holder from bottom side with the help of 2 grub screws.

**10. Spare parts (Actuator):**

<b>eVALV Spare Codes</b>		
<b>KIT NAME</b>	<b>DESCRIPTION</b>	<b>SPARE CODE</b>
<b>ACTUATOR CLAMPING NUT</b>	VALVE SPARES,15-25NB EVALV ACTUATOR CLAMP NUT KIT, SPARE CONSISTS OF ACTUATOR CLAMP NUT PACK OF 2 NO'S	SPARE-1525EVALV-ACNKIT
	VALVE SPARES,40-50NB EVALV ACTUATOR CLAMP NUT KIT, SPARE CONSISTS OF ACTUATOR CLAMP NUT PACK OF 2 NO'S	SPARE-4050EVALV-ACNKIT
	VALVE SPARES,80-100NB EVALV ACTUATOR CLAMP NUT KIT, SPARE CONSISTS OF ACTUATOR CLAMP NUT PACK OF 2 NO'S	SPARE-80100EVALV-ACNKIT
<b>STEM STEM SEAL KITS</b>	VALVE SPARES,15-25NB EVALV SEAL KIT,SPARE CONSISTS OF GALND NUT-1NO.,BODY-SEAT GASKETS-1 NO EACH,TOP& BOTTOM O-RING-1NO EACH ,GLAND & GUIDE BUSH -1 NO EACH,SCRAPPER RING-1NO,CHEVRON SET,BEARING-1NO,SPACER-3 NO	SPARE-1525EVALV-SEALKIT
	VALVE SPARES,40-50NB EVALV SEAL KIT,SPARE CONSISTS OF GALND NUT-1NO.,BODY-SEAT GASKETS-1 NO EACH,TOP& BOTTOM O-RING-1NO EACH ,GLAND & GUIDE BUSH -1 NO EACH,SCRAPPER RING-1NO,CHEVRON SET,BEARING-1NO,SPACER-3 NO	SPARE-4050EVALV-SEALKIT
	VALVE SPARES,80-100NB EVALV SEAL KIT,SPARE CONSISTS OF GALND NUT-1NO.,BODY-SEAT GASKETS-1 NO EACH,TOP& BOTTOM O-RING-1NO EACH ,GLAND & GUIDE BUSH -1 NO EACH,SCRAPPER RING-1NO,CHEVRON SET,BEARING-1NO,SPACER-3 NO	SPARE-80100EVALV-SEALKIT

KIT NAME	DESCRIPTION	SPARE CODE
<b>PLUG-STEM AND SEAT KIT</b>	VALVE SPARES,15NB EVALV PLUG SEAT KIT ,SPARE CONSISTS OF PLUG ,SEAT ,SEAT GASKET & BODY GASKET 1 NO EACH	SPARE-15EVALV-PSKIT
	VALVE SPARES,25NB EVALV PLUG SEAT KIT ,SPARE CONSISTS OF PLUG ,SEAT ,SEAT GASKET & BODY GASKET 1 NO EACH	SPARE-25EVALV-PSKIT
	VALVE SPARES,40NB EVALV PLUG SEAT KIT ,SPARE CONSISTS OF PLUG ,SEAT ,SEAT GASKET & BODY GASKET 1 NO EACH	SPARE-40EVALV-PSKIT
	VALVE SPARES,50NB EVALV PLUG SEAT KIT ,SPARE CONSISTS OF PLUG ,SEAT ,SEAT GASKET & BODY GASKET 1 NO EACH	SPARE-50EVALV-PSKIT
	VALVE SPARES,80NB EVALV PLUG SEAT KIT ,SPARE CONSISTS OF PLUG ,SEAT ,SEAT GASKET & BODY GASKET 1 NO EACH	SPARE-80EVALV-PSKIT
	VALVE SPARES,100NB EVALV PLUG SEAT KIT ,SPARE CONSISTS OF PLUG ,SEAT ,SEAT GASKET & BODY GASKET 1 NO EACH	SPARE-100EVALV-PSKIT
<b>GASKET KIT</b>	VALVE SPARES,15-25NB EVALV GASKET KIT ,SPARE CONSISTS OF SEAT GASKET & BODY GASKET 2 NO'S EACH	SPARE-1525EVALV-GKIT
	VALVE SPARES,40-50NB EVALV GASKET KIT ,SPARE CONSISTS OF SEAT GASKET & BODY GASKET 2 NO'S EACH	SPARE-4050EVALV-GKIT
	VALVE SPARES,80NB EVALV GASKET KIT ,SPARE CONSISTS OF SEAT GASKET & BODY GASKET 2 NO'S EACH	SPARE-80EVALV-GKIT
	VALVE SPARES,100NB EVALV GASKET KIT ,SPARE CONSISTS OF SEAT GASKET & BODY GASKET 2 NO'S EACH	SPARE-100EVALV-GKIT



<b>A0 Actuator Spare Codes</b>		
<b>KIT NAME</b>	<b>DESCRIPTION</b>	<b>SPARE CODE</b>
<b>REPAIR KIT</b>	EVALV A0 ACTUATOR, SPARE TYPE : REPAIR KIT, SPARE CONSIST OF : DIAPHRAGM ASSEMBLY NC WITH & WITHOUT HANDWHEEL, ONE SPRING & WDB SEAL HOLDER ASEMBLY [PACK OF 1	SPARE-EVALV-A0-20NC1-RKIT
	EVALV A0 ACTUATOR, SPARE TYPE : REPAIR KIT, SPARE CONSIST OF : DIAPHRAGM ASSEMBLY NO WITH & WITHOUT HANDWHEEL, ONE SPRING & WDB SEAL HOLDER ASEMBLY [PACK OF 1]	SPARE-EVALV-A0-20NO1-RKIT
	EVALV A0 ACTUATOR, SPARE TYPE : REPAIR KIT, SPARE CONSIST OF : DIAPHRAGM ASSEMBLY NC WITH & WITHOUT HANDWHEEL, TWO SPRINGS & WDB SEAL HOLDER ASEMBLY [ PACK OF 1]	SPARE-EVALV-A0-20NC2-RKIT
	EVALV A0 ACTUATOR, SPARE TYPE : REPAIR KIT, SPARE CONSIST OF : DIAPHRAGM ASSEMBLY NO WITH & WITHOUT HANDWHEEL, TWO SPRINGS & WDB SEAL HOLDER ASEMBLY [PACK OF 1]	SPARE-EVALV-A0-20NO2-RKIT
<b>SPRING KIT</b>	EVALV A0 ACTUATOR, SPARE TYPE : SPRING KIT, SPARE CONSIST OF : EXTERNAL SPRING (1 NO) [PACK OF 1]	SPARE-EVALV-A0-20NCNO1-SKIT
	EVALV A0 ACTUATOR, SPARE TYPE : SPRING KIT, SPARE CONSIST OF : EXTERNAL SPRING (1 NO), INTERNAL SPRING (1NO) [PACK OF 1]	SPARE-EVALV-A0-20NCNO2-SKIT
<b>DIAPHRAGM KIT</b>	A0 ACTUATOR, SPARE TYPE : DIAPHRAGM KIT, SPARE CONSIST OF : DIAPHRAGM(NC&NO), STEM O RING (1 NO) [PACK OF 1]	SPARE-EVALV-A0-DKIT
<b>WDB SEAL HOLDER ASSLY KIT</b>	A0 ACTUATOR, SPARE TYPE : WDB SEAL HOLDER ASSLY KIT, SPARE CONSIST OF : WDB SEAL HOLDER(NC&NO), WDB SEAL, DU BEARING & O RING (2 NOS) [PACK OF 1]	SPARE-EVALV-A0-WKIT
<b>COUPLING SUB-ASSEMBLY KIT</b>	EVALV A0-A1 ACTUATOR, SPARE TYPE : COUPLING SUB-ASSEMBLY KIT, SPARE CONSIST OF : UPPER COUPLING, LOWER COUPLING, LOCK NUT M10 (1 NO), ALLEN BOLTCKIT M6 (2 NOS), SPRING WASHER (2NOS) [PACK OF 1]	SPARE-EVALV-A0A1-

KIT NAME	DESCRIPTION	SPARE CODE
<b>POSITIONER MOUNTING KIT</b>	EVALV A0-A1 ACTUATOR, SPARE TYPE:POS. MOUNTING KIT,SPARE CONSIST OF:C-LINK, FEEDBACK LINK,L-BKT,A BOLT M5(2), MOUNTING BKT,PNEUMATIC-MALE CONNECTOR (1/4" X 8), MALE ELBOW (1/4" x 8)(3),TUBEING(0.5M),H BOLT M8(2) [PACK OF 1]	SPARE-EVALV-A0A1-PMKIT
<b>STEM KIT</b>	EVALV A0 ACTUATOR, SPARE TYPE : STEM KIT, SPARE CONSIST OF UPPER STEM NC, WDB SEAL (2 NOS) [PACK OF 1]	SPARE-EVALV-A0-NC-STKIT
	EVALV A0 ACTUATOR, SPARE TYPE : STEM KIT, SPARE CONSIST OFLOWER STEM NO, WDB SEAL (2 NOS) [PACK OF 1]	SPARE-EVALV-A0-NO-STKIT
<b>SEAL KIT</b>	EVALV A0 ACTUATOR, SPARE TYPE : SEAL KIT, SPARE CONSIST OF : STEM O RING (2 NOS), O RING(2 NOS), O RING,ID-29.74MM(2 NOS), WDB SEAL, GASKET(2 NOS) [PACK OF 1]	SPARE-EVALV-A0-SLKIT
<b>HANDWHEEL KIT</b>	EVALV A0 ACTUATOR, SPARE TYPE : HANDWHEEL KIT, SPARE CONSIST OF : GASKET, O-RING HOLDER (NC), SOC.HD.SCREW M5 (4 NOS), O RING, HANDWHEEL WELDING ASSEMBLY(WA), THRUST BEARING, PLAIN WASHER,OD-24MM, HANDWHEEL CAP [PACK OF 1]	SPARE-EVALV-A0-NC-HKIT
	EVALV A0 ACTUATOR, SPARE TYPE:HANDWHEEL KIT,SPARE CONSIST OF: COMPLETE HANDWHEEL ASSLY (NO)	SPARE-EVALV-A0-NO-HKIT
<b>HARDWARE KIT</b>	EVALV A0 ACTUATOR, SPARE TYPE : HARDWARE KIT, SPARE CONSIST OF :A0 ACTUATOR ALL HARDWARE ITEMS [PACK OF 1]	SPARE-EVALV-A0-HAKIT

<b>A1 Actuator Spare Codes</b>		
<b>KIT NAME</b>	<b>DESCRIPTION</b>	<b>SPARE CODE</b>
<b>REPAIR KIT</b>	EVALV A1 ACTUATOR, SPARE TYPE : REPAIR KIT, SPARE CONSIST OF : DIAPHRAGM ASSEMBLY NC WITH & WITHOUT HANDWHEEL,THREE SPRINGS & WDB SEAL HOLDER ASEMBLY [PACK OF 1]	SPARE-EVALV-A1-20NC3-RKIT
	EVALV A1 ACTUATOR, SPARE TYPE : REPAIR KIT, SPARE CONSIST OF : DIAPHRAGM ASSEMBLY NO WITH & WITHOUT HANDWHEEL, THREE SPRINGS & WDB SEAL HOLDER ASEMBLY [PACK OF 1]	SPARE-EVALV-A1-20NO3-RKIT
	EVALV A1 ACTUATOR, SPARE TYPE : REPAIR KIT, SPARE CONSIST OF : DIAPHRAGM ASSEMBLY NC WITH & WITHOUT HANDWHEEL, SIX SPRINGS & WDB SEAL HOLDER ASEMBLY [PACK OF 1]	SPARE-EVALV-A1-20NC6-RKIT
	EVALV A1 ACTUATOR, SPARE TYPE : REPAIR KIT, SPARE CONSIST OF : DIAPHRAGM ASSEMBLY NO WITH & WITHOUT HANDWHEEL, SIX SPRINGS & WDB SEAL HOLDER ASEMBLY [PACK OF 1]	SPARE-EVALV-A1-20NO6-RKIT
<b>SPRING KIT</b>	EVALV A1 ACTUATOR, SPARE TYPE : SPRING KIT, SPARE CONSIST OF : EXTERNAL SPRING (3 NO) [PACK OF 1]	SPARE-EVALV-A1-20NCNO3-SKIT
	EVALV A1 ACTUATOR, SPARE TYPE : SPRING KIT, SPARE CONSIST OF : EXTERNAL SPRING (3 NO), INTERNAL SPRING (3 NO) [PACK OF 1]	SPARE-EVALV-A1-20NCNO6-SKIT
<b>DIAPHRAGM KIT</b>	A1 ACTUATOR, SPARE TYPE : DIAPHRAGM KIT, SPARE CONSIST OF : DIAPHRAGM(NC&NO), STEM O RING (1 NO) [PACK OF 1]	SPARE-EVALV-A1-DKIT
<b>WDB SEAL HOLDER ASSLY KIT</b>	A1 ACTUATOR, SPARE TYPE : WDB SEAL HOLDER ASSLY KIT, SPARE CONSIST OF : WDB SEAL HOLDER(NC&NO)(2), WDB SEAL(2), DU BEARING & O RING (2 NOS) [PACK OF 1]	SPARE-EVALV-A1-WKIT
<b>STEM KIT</b>	EVALV A1 ACTUATOR, SPARE TYPE : STEM KIT, SPARE CONSIST OF UPPER STEM NC, STEM SEAL (2 NOS) [PACK OF 1]	SPARE-EVALV-A1-NC-STKIT
	EVALV A1 ACTUATOR, SPARE TYPE : STEM KIT, SPARE CONSIST OFLOWER STEM NO, STEM SEAL (2 NOS) [PACK OF 1]	SPARE-EVALV-A1-NO-STKIT

KIT NAME	DESCRIPTION	SPARE CODE
SEAL KIT	EVALV A0 ACTUATOR, SPARE TYPE : SEAL KIT, SPARE CONSIST OF : STEM O RING (2 NOS), O RING(2 NOS), O RING,ID-29.74MM(2 NOS), STEM SEAL, GASKET(2 NOS), LIP SEAL HOLDER [PACK OF 1]	SPARE-EVALV-A1-SLKIT
HANDWHEEL KIT	EVALV A1 ACTUATOR, SPARE TYPE:HANDWHEEL KIT,SPARE CONSIST OF: COMPLETE HANDWHEEL ASSLY (NC)	SPARE-EVALV-A1-NC-HKIT
	EVALV A1 ACTUATOR, SPARE TYPE:HANDWHEEL KIT,SPARE CONSIST OF: COMPLETE HANDWHEEL ASSLY (NO)	SPARE-EVALV-A1-NO-HKIT
HARDWARE KIT	EVALV A1 ACTUATOR, SPARE TYPE : HARDWARE KIT, SPARE CONSIST OF :A1 ACTUATOR ALL HARDWARE ITEMS [PACK OF 1]	SPARE-EVALV-A1-HAKIT

A2 Actuator Spare Codes		
KIT NAME	DESCRIPTION	SPARE CODE
REPAIR KIT	EVALV A2 ACTUATOR, SPARE TYPE : REPAIR KIT, SPARE CONSIST OF : DIAPHRAGM ASSEMBLY NC WITH & WITHOUT HANDWHEEL,SIX EXTERNAL SPRINGS & WDB SEAL HOLDER ASEMBLY [PACK OF 1]	SPARE-EVALV-A2-30NC6-RKIT
	EVALV A2 ACTUATOR, SPARE TYPE : REPAIR KIT, SPARE CONSIST OF : DIAPHRAGM ASSEMBLY NO WITH & WITHOUT HANDWHEEL, SIX EXTERNAL SPRINGS & WDB SEAL HOLDER ASEMBLY [PACK OF 1]	SPARE-EVALV-A2-30NO6-RKIT
	EVALV A2 ACTUATOR, SPARE TYPE : REPAIR KIT, SPARE CONSIST OF : DIAPHRAGM ASSEMBLY NC WITH & WITHOUT HANDWHEEL, SIX EXTERNAL & SIX INTERNAL SPRINGS & WDB SEAL HOLDER ASEMBLY [ PACK OF 1]	SPARE-EVALV-A2-30NC12-RKIT
	EVALV A2 ACTUATOR, SPARE TYPE : REPAIR KIT, SPARE CONSIST OF : DIAPHRAGM ASSEMBLY NO WITH & WITHOUT HANDWHEEL, SIX EXTERNAL & SIX INTERNAL SPRINGS & WDB SEAL HOLDER ASEMBLY [ PACK OF 1]	SPARE-EVALV-A2-30NO12-RKIT

KIT NAME	DESCRIPTION	SPARE CODE
<b>SPRING KIT</b>	EVALV A2 ACTUATOR, SPARE TYPE : SPRING KIT, SPARE CONSIST OF : EXTERNAL SPRING (6 NO) [PACK OF 1]	SPARE-EVALV-A2-30NCNO6-SKIT
	EVALV A2 ACTUATOR, SPARE TYPE : SPRING KIT, SPARE CONSIST OF : EXTERNAL SPRING (6 NO), INTERNAL SPRING (6 NO) [PACK OF 1]	SPARE-EVALV-A2-30NCNO12-SKIT
<b>DIAPHRAGM KIT</b>	EVALV A2 ACTUATOR, SPARE TYPE : DIAPHRAGM KIT, SPARE CONSIST OF : DIAPHRAGM(NC&NO), STEM O RING (1 NO) [PACK OF 1]	SPARE-EVALV-A2-DKIT
<b>WDB SEAL HOLDER ASSLY KIT</b>	EVALV A2 ACTUATOR, SPARE TYPE : WDB SEAL HOLDER ASSLY KIT, SPARE CONSIST OF : WDB SEAL HOLDER-1.5MM PITCH(NC)(2), WDB SEAL(2), DU BEARING & O RING (2 NOS) [PACK OF 1]	SPARE-EVALV-A2NC-WKIT
	EVALV A2 ACTUATOR, SPARE TYPE : WDB SEAL HOLDER ASSLY KIT, SPARE CONSIST OF : WDB SEAL HOLDER-2MM PITCH(NO)(2), WDB SEAL(2), DU BEARING & O RING (2 NOS) [PACK OF 1]	SPARE-EVALV-A2NO-WKIT
<b>COUPLING SUB-ASSEMBLY KIT</b>	EVALV A2 ACTUATOR, SPARE TYPE : COUPLING SUB-ASSEMBLY KIT, SPARE CONSIST OF : UPPER COUPLING, LOWER COUPLING, LOCK NUT M10 (2 NOS), ALLEN BOLT M6 (2 NOS) [PACK OF 1]	SPARE-EVALV-A2-CKIT
<b>POSITIONER MOUNTING KIT</b>	EVALV A2 ACTUATOR, SPARE TYPE:POS. MOUNTING KIT,SPARE CONSIST OF:C-LINK, FEEDBACK LINK,L-BKT,A BOLT M5(2), MOUNTING BKT,PNEUMATIC-MALE CONNECTOR (1/4" X 8), MALE ELBOW (1/4" x 8)(3),TUBEING(0.7M),H BOLT M8(2) [PACK OF 1]	SPARE-EVALV-A2-PMKIT
<b>STEM KIT</b>	EVALV A2 ACTUATOR, SPARE TYPE : STEM KIT, SPARE CONSIST OF UPPER STEM NC, STEM SEAL (2 NOS) [PACK OF 1]	SPARE-EVALV-A2-NC-STKIT
	EVALV A2 ACTUATOR, SPARE TYPE : STEM KIT, SPARE CONSIST OF LOWER STEM NO, STEM SEAL (2 NOS) [PACK OF 1]	SPARE-EVALV-A2-NO-STKIT

KIT NAME	DESCRIPTION	SPARE CODE
<b>SEAL KIT</b>	EVALV A2 ACTUATOR, SPARE TYPE : SEAL KIT, SPARE CONSIST OF : STEM O RING (2 NOS), O RING C/S 5MM(2 NOS), LIP SEAL HOLDER [PACK OF 1]	SPARE-EVALV-A2-SLKIT
<b>HARDWARE KIT</b>	EVALV A2 ACTUATOR, SPARE TYPE : HARDWARE KIT, SPARE CONSIST OF :A2 ACTUATOR ALL HARDWARE ITEMS [PACK OF 1]	SPARE-EVALV-A2-HAKIT

**11. Warranty Period:**

As per the ordering information and agreement in the contract.



[www.forbesmarshall.com](http://www.forbesmarshall.com)

Forbes Marshall Arca

Codel International

Krohne Marshall

Forbes Vyncke

Forbes Marshall Steam Systems

**A: Forbes Marshall Pvt. Ltd.**

Opp. 106th Milestone, CTS 2220,  
Mumbai-Pune Road, Kasarwadi,  
Pune MH 411034 INDIA

**P:** +91(0)20-68138555

**F:** +91(0)20-68138402

**E:** [ccmidc@forbesmarshall.com](mailto:ccmidc@forbesmarshall.com)

**Forbes Marshall International Pte. Ltd.**

16A, Tuas Avenue 1,  
#05-21, JTC Space @Tuas  
Singapore - 639533

**P:** +65 6219 3890

**CIN No:** U28996PN1985PTC037806