

Installation and Maintenance Manual

Forbes Marshall Tracer Line Trap / Forbes Marshall Air Vent

FMTLT53/FMAV53

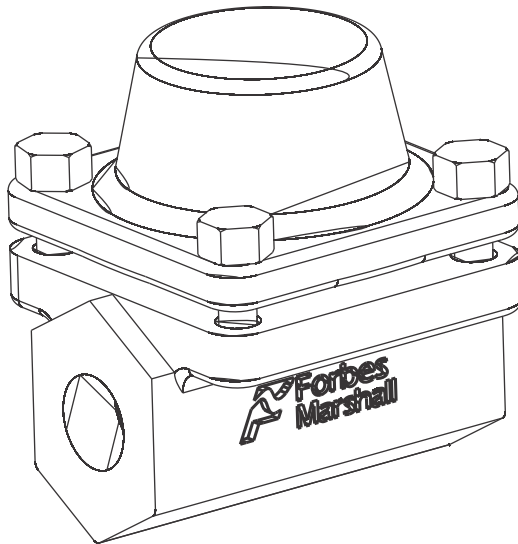

Table of Contents

1.	Preface.....	1
2.	Important Safety Notes.....	1
3.	Brief Product Description.....	3
4.	Product Working Principle.....	5
5.	Installation Guidelines.....	6
6.	Start-up and Commissioning.....	7
7.	Maintenance Guidelines.....	7
8.	Troubleshooting.....	8
8.	Available Spares.....	9
9.	Warranty Period.....	10

PLEASE NOTE - Throughout this manual this cautionary symbol is used to describe a potential damage or injury that might occur if the safety considerations are overlooked. This symbol denotes **CAUTION, WARNING** or **DANGER**.



1. Preface:

This manual is intended for anyone using, commissioning, servicing, or disposing the below mentioned products safely and efficiently.

Forbes Marshall Tracer Line Trap [FMTLT53] / Forbes Marshall Air Vent [FMAV53]

Size: DN15 (1/2") and DN20 (3/4")

PLEASE NOTE:

Throughout this manual the following cautionary symbol is used to describe a potential damage or injury that might occur if the safety considerations are overlooked.

2. Important Safety Notes:



Read this section carefully before installing/operating/maintaining the product. The precautions listed in this manual are provided for personnel and equipment safety.

Furthermore, Forbes Marshall accepts no responsibility for accidents or damage occurring as a result of failure to observe these precautions. Note that the product is designed to perform for non-contaminated fluids only. A contamination in the form of chemical, foreign particle etc. can lead to problem with product performance and life of the product.

If these products in compliance with the operating instructions are, properly installed, commissioned, maintained and installed by qualified personnel (refer Section 2.7), the safety operations of these products can be guaranteed. General instructions for proper use of tools and safety of equipment's, pipeline and plant construction must also be complied with.

2.1 Intended use:

Check if the product is suitable for intended use/ application by referring to the installation and maintenance instructions, name plates and technical information sheets. (TIS)

- i) The product is suitable for use as defined in the technical information sheet. In case the need arises to use the product on any other fluid please contact Forbes Marshall for assistance.
- ii) Check for the suitability in conformance to the limiting conditions specified in technical information sheet of the product.
- iii) The correct installation and direction of fluid flow has to be determined.
- iv) Forbes Marshall products are not intended to resist external stresses, hence necessary precautions to be taken to minimize the same.

2.2 Accessibility and Lighting:

Safe accessibility and working conditions are to be ensured prior to working on the product.

2.3 Hazardous environment and media:

The product has to be protected from hazardous environment and check to ensure that no hazardous liquids or gases pass through the product.

2.4 Depressurizing of systems and normalizing of temperature:

Ensure isolation and safety venting of any pressure to the atmospheric pressure. Even if the pressure gauge indicates zero, do not make an assumption that the system has been depressurized. To avoid danger of burns allow temperature to normalize after isolation.

2.5 Tools and consumables:

Ensure you have appropriate tools and / or consumables available before starting the work. Use of original Forbes Marshall replacement parts is recommended.

2.6 Protective clothing:

Consider for the requirement of any protective clothing for you/ or others in the vicinity for protection against hazards of temperature (high or low), chemicals, radiation, dangers to eyes and face, noise and falling objects

2.7 Permits to work:

All work to be carried out under supervision of a competent person. Training should be imparted to operating personnel on correct usage of product as per Installation and Maintenance instruction. "Permit to work" to be complied with (wherever applicable), in case of absence of this system a responsible person should have complete information and knowledge on what work is going on and where required, arrange to have an assistant with his primary goal and responsibility being safety. "Warning Notices" should be posted wherever necessary.

2.8 Handling:

There is a risk of injury if heavy products are handled manually. Analyze the risk and use appropriate handling method by taking into consideration the task, individual, the working environment and the load.

2.9 Freezing:

Provision should be made to protect systems which are not self-draining, against frost damage (in environment where they may be exposed to temperatures below freezing point) to be made.

2.10 Product Disposal:

It is necessary to dispose this product only in accordance with local regulations at the authorized, qualified collecting point specified for equipment's and its parts—Please refer the part details mentioned in the material table of this manual. Please follow all waste disposal guidelines (Management & Handling) as published by local governing authorities in India & abroad.

2.11 Returning products:

Customers and Stockist are reminded that, when returning products to Forbes Marshall they must provide information on any hazards and the precautions to be taken due to contamination residues or mechanical damage which may present a health, safety or environmental risk.

This information must be provided in writing including Health and Safety data sheets relating to any substances identified as hazardous or potentially hazardous.

3. Brief Product Description:

3.1 Description:

The Forbes Marshall Tracer Line Trap FMTLT53 / Air Vent FMAV53 can be used for air venting application from steam mainlines or as a steam trap for tracer line application for removal of sub cooled condensate. It comes with an inbuilt flat strainer screen having 1/32" diameter perforations.

3.2 Size and End Connections:

1/2" and 3/4"

BSPT/NPT, socket weldable ends

Note : Available with IBR certificate on request

3.3 Limiting Conditions:

PMA-Max allowable pressure	725 Psig @ 122 °F
TMA-Max allowable temperature	725 °F @ 508 Psig
PMO-Max operating pressure	464 Psig
TMO-Max operating temperature	549 °F
Cold hydraulic test pressure	609 Psig

3.4 Operating Range:

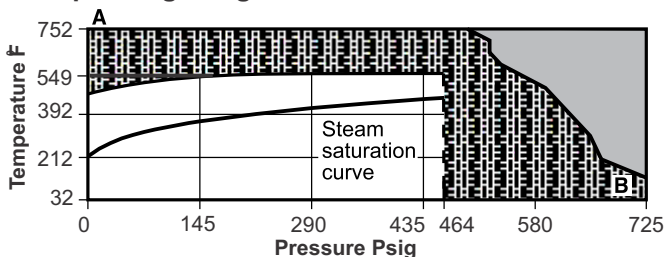

 The product **must not** be used in this region.

 The product should not be used in this region or beyond its operating range as damage to the internals may occur.

A - B Screwed & Socket Weld Ends

Thermopod Filling for FMTLT53:

As a standard, the FMTLT53 trap is supplied with filling 'U', which will operate approximately 75 °F below steam saturation temperature. As an optional alternative, the trap can be supplied with filling 'T', which will operate approximately 54 °F below steam saturation temperature or filling 'C', which will operate approximately 43 °F below the steam saturation curve.

Note: If the alternative thermopod is required this must be clearly stated in the order e.g. capsule to have 'U' fill or 'T' fill.

Thermopod Filling for FMAV53:

As a standard the FMAV53 is supplied with filling 'U'.

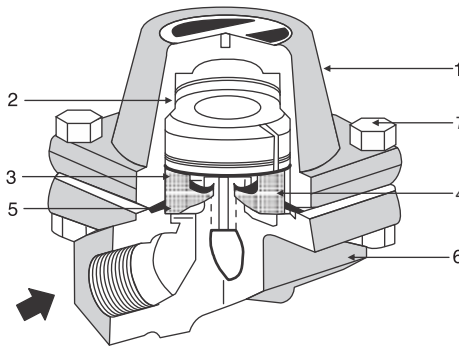

Figure 1: Forbes Marshall Tracer Line Trap / Forbes Marshall Air Vent

Material:

No	Part	Material	Standard
1	Cover	Forged	ASTM A105 Carbon Steel
2	Thermopod	Stainless Steel	AISI 304
3	Valve Seat	Stainless Steel	ASTM A276, Type 316
4	Strainer Screen	Stainless Steel	ASTM A240, Type 304
5	Cover Gasket	Reinforced Exfoliated Graphite	
6	Body	Forged Carbon Steel	ASTM A105
7	Cover Bolts and Nuts	Carbon Steel	IS 1367, HT Gr.8.8 (ASTM A193 B7)

Note: Material specification mentioned in bracket are for reference only.

3.5 Product Dimension and Drawing:

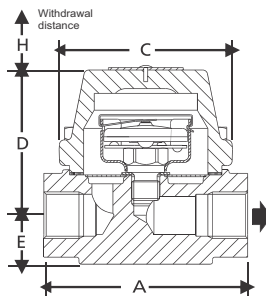
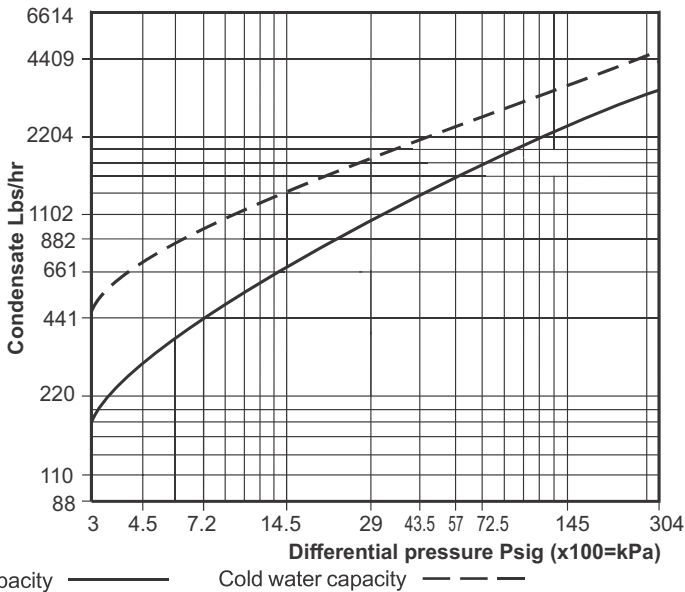

Figure 2: Dimensional drawing of FMTLT53/FMAV53

Dimensions (approx. in Inches):

Size	A	C	D	E	H	Wt. (Lbs)
1/2"	3.6	3.1	2.8	1	1.6	4.4
3/4"	3.6	3.1	2.8	1	1.6	4.4

Capacity Chart:



4. Product Working Principle:

The Forbes Marshall Tracer Line Trap / Air Vent works on thermostatic principle operates on the steam temperature difference from sub-cooled condensate and air. Steam increases the pressure inside the thermostatic element i. e. thermopod, causing the trap to close. As condensate and non-condensate gases surrounding the thermopod, the temperature begins to drop and the thermopod contracts and opens the valve.

4.1 Operations of Forbes Marshall Tracer Line Trap / Air Vent : (Refer Figure 1)

1. The operating thermostatic element is a thermopod (2) containing a small quantity of a hydrocarbon liquid with a boiling point below that of water.
2. When steam is turned on during start-up, air and sub-cooled condensate is discharged as the valve is off its seat (3) and is wide open.
3. As condensate passes through the tracer line trap, heat is transferred to the hydrocarbon liquid in the thermopod (2). The hydrocarbon liquid boils (based on thermopod (2) selected) before steam reaches the trap.
4. The vapour pressure within the thermopod (2) causes it to expand which closes the valve seat (3) and trap remains shut.
5. Heat loss from the trap cools the water surrounding the thermopod (2), the hydrocarbon liquid condenses and the thermopod (2) contracts, opening the valve seat (3) and releasing condensate until steam temperature approaches again at which the cycle is repeated.

5. Installation Guidelines:



Note: Before implementing any installations observe the 'Important Safety notes' in section 2. Referring to the Installation and Maintenance Instructions, name-plate and Technical Information Sheet, check that the product is suitable for the intended installation.

1. Before installing the Forbes Marshall Tracer Line Trap/Air Vent, flush the inlet piping to remove all dirt and oil.
2. Remove protective covers from all connections where appropriate, before installation.
3. The Forbes Marshall Tracer Line Trap/Air Vent should be installed on horizontal plane and the cover at the top, preferably with a drip leg immediately preceding the steam trap when installed on tracer line.
4. It is recommended that a non-return valve is fitted when discharging condensate into return lines where backpressure is experienced. It is also recommended that a diffuser is fitted when discharging to atmosphere.
5. Suitable isolation valves must be installed to allow for safe maintenance and steam trap replacement.
6. Open isolation valves slowly until normal operating conditions are achieved. Check for leaks and correct operation.
7. Installation locations for Forbes Marshall Air Vent [FMAV53] when used in tracer lines and air vent applications as shown in figure 3 and 4 respectively.

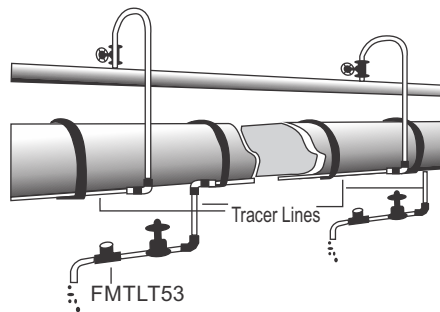

Figure 3: Installation of Forbes Marshall Tracer Line Trap in tracer line

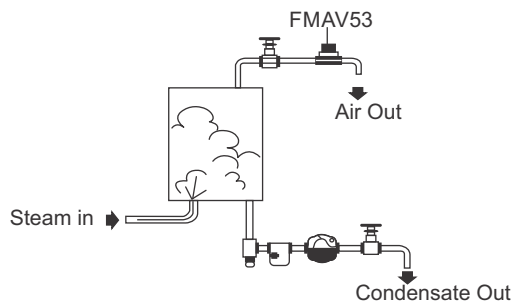

Figure 4: Installation of Forbes Marshall Air Vent for air vent

6. Start-up and Commissioning:

6.1. Flushing of lines:

As a part of pre-installation, all fluid handling equipment particularly piping should be thoroughly cleaned of scale and the internal debris which accumulates during construction. This is accomplished by blowing or flushing with air, steam, water and other suitable medium.

Follow these steps to carry out the flushing.

1. Close the isolation valve and open the bypass isolation valve.
2. Drain the condensate 10 -15 minutes or until clear condensate starts coming out, whichever is earlier.
3. Now slowly close the bypass isolation valve and open the trap isolation valve.

Note: For a detailed procedure on flushing of lines please visit Forbes Marshall website.

6.2. Commissioning:

After installation or maintenance ensure that the system is fully functioning by confirming fluid is passing through it.

1. After flushing of lines is complete, ensure that bypass valve closed and isolation valve is opened.
2. Check for leaks and attend, if any.

7. Maintenance Guidelines:



Note: Before undertaking any maintenance of the product it must be isolated from both supply line and return line and ensure pressure is normalized to atmosphere. The product should then be allowed to cool. When re-assembling ensure that all joint faces are clean.

7.1. Routine and Preventive Maintenance:

Please refer to the maintenance schedule mentioned in the table below to undertake routine maintenance of the Forbes Marshall Tracer Line Trap / Air Vent.

No.	PARAMETER TO BE CHECKED	FREQUENCY FOR CHECKING VARIOUS PARAMETERS						
		Immediate	Daily	Weekly	Monthly	Quarterly	Half Yearly	Annually
1	Test trap			Y				
2	Repair / Replace steam traps - when testing shows leaks	Y						
3	Clean internals of [FMTLT53/FMAV53]						Y	
4	Visual Inspection for leakages		Y					
5	Arresting any other leaks	Y						

7.2. Tool Kit:

To carry out any maintenance on the [FMTLT53/FMAV53] please use the tools mentioned below:

Size	Component	Tool used & size
1/2", 3/4"	Fixture 86139	-
	1/32" perforated screen in the body	-
	Rocol on threads of the seat	-
	Valve seat	Box spanner of 11/16" (A/F)
	4, 5/16" bolts and nuts	Box spanner of 1/2" (A/F)

7.3. Recommended tightening torques:

Item	Torques
Cover Bolts (7)	18 -26 Ft-lbsf

Table1. Recommended tightening torques.

7.4. Procedure to fit or replace thermopod and seat assembly: (Refer Figure 1)

1. Remove the cover from body by unscrewing the cover bolts & nuts (7) using box spanner of 1".
2. Unscrew the thermopod and valve seat assembly set.
3. Remove the restraining clip from the thermopod and seat assembly and lift the thermopod (2) and spacer upwards & outwards.
4. Remove the gasket (5), and clean the internals using WD40 liquid spray and clean with lint free cloth.
5. After cleaning refit the thermopod & seat assembly and insert new cover gasket (5) make sure that the strainer screen (4) is correctly located.
6. Ensure that the cover bolts are tightened evenly. The recommended torques for tightening as shown in table 1.
7. When maintenance is complete, open isolation valves slowly until the normal pressure is obtained. Checks for leaks and attend, if any.

7.5. Procedure to clean or replace the strainer screen: (Refer Figure 1)

1. Remove the cover from body by unscrewing the cover bolts and nuts (7) using a 1/2" box spanner.
2. Replace with new strainer screen (4).
3. Ensure that the cover bolts are tightened evenly. The recommended torques for tightening as shown in Table 1.
4. When maintenance is complete, open isolation valves slowly until normal pressure is obtained. Checks for leaks and attend, if any.

8. Troubleshooting:

If the expected performance is unachievable after installation of the [FMTLT53 /FMAV53], check the following points for appropriate corrective measures.

Failure Mode	Possible Cause	Remedy
No condensate discharge (blocked).	Strainer Screen is clogged with rust or scale	Clean Strainer Screen if screen is rusted with new one.
	Valve seat is blocked.	Clean the valve seat and thermopod ball surface then re-assemble the steam trap.
	Thermopod may be over extended due to excessive internal pressure caused by superheat steam making it impossible for the thermopod ball (valve head) to lift off from valve seat.	Replace the thermopod assembly;
	Improper Installation	Check installation fluid flow direction same as arrow on the Tracer Line Trap / Air Vent Body.

Failure Mode	Possible Cause	Remedy
Steam leakage or blowing from the outlet	Foreign material has built-up between thermopod ball (valve head) and valve seat.	Clean the valve seat and thermopod ball surface then re-assemble the steam trap; check for any steam leak. If valve seat is damaged, replace the valve seat assembly.
	Valve seat and thermopod ball (valve head) does not shut – off tightly.	Clean both valve seat and thermopod ball after that seat stamping* should be done.
	Check if the thermopod is in good condition, Thermopod should not be compressible when cool; any flabbiness indicates failure.	Replace with new thermopod assembly.
	Valve seat is wire drawing.	Replace with new valve seat.
	Steam trap installation in vertical plane	The trap is designed for installation with the thermopod in a horizontal plane with the drip leg immediately preceding the trap.
Steam leaks from body & top cover joint	Improper Tightening torque on cover nut	Tighten to the proper torque as mention in table 1.
	Cover gasket deterioration or damage	Replace with new cover gasket.

Seat Stamping* Procedure: Place valve seat on the fixture with thermopod on the valve seat (thermopod ball side resting on the valve seat orifice) and tap slightly on the center with a mallet. Due to stamping a seating surface is formed on the valve seat orifice. **Note:** Never attempt to modify the product. When replacing part with new, use the spare parts listed in Section 9.

9. Available Spares:

The spare parts available are shown in heavy outline. Parts drawn in broken line are not supplied as spares.

Spares	Part No.	Spare Code
Thermopod & seat assembly set (State thermopod filling) 'U' / STD fill	A	S2016338
Thermopod & seat assembly set (State thermopod filling) 'T' / SUB fill	A	S2016280
Thermopod & seat assembly set (State thermopod filling) 'C' / SUB fill	A	S2031914
Strainer screen & gasket kit (Pack of 5)	B,C	S2016367

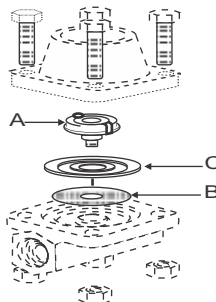

Figure 5: Parts available as spares (Heavy line) of [FMTLT53/FMAV53]

How to Order: Example : Forbes Marshall Tracer Line Trap 1/2" FMTLT53 having screwed NPT connections with Thermopod 'U' filling. **Or** Forbes Marshall Air Vent 1/2" FMAV53 having screwed NPT connections.

How to Order Spares: Always order spares by using the description given in the column above, headed "Available Spares", and stating the size and type of steam trap. For codes refer user manual.

10. Warranty Period:

As per ordering information and agreements in the contract.



www.forbesmarshall.com

Forbes Marshall Arca

Codel International

Krohne Marshall

Forbes Vyncke

Forbes Marshall Steam Systems

A: Forbes Marshall Pvt. Ltd.

Opp. 106th Milestone, CTS 2220,
Mumbai-Pune Road, Kasarwadi,
Pune MH 411034 INDIA

P: +91(0)20-68138555

F: +91(0)20-68138402

E: ccmidc@forbesmarshall.com

Forbes Marshall International Pte. Ltd.

16A, Tuas Avenue 1,
#05-21, JTC Space @Tuas
Singapore - 639533

P: +65 6219 3890

CIN No: U28996PN1985PTC037806