

# Installation and Maintenance Manual

## Clean Steam Moisture Separator

CSSEP

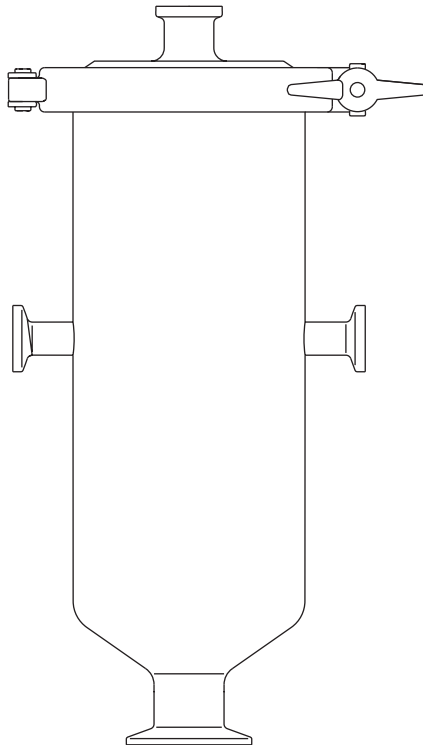

## Table of Contents

1.	Preface .....	1
2.	Important Safety Notes.....	1
3.	Brief Product Information .....	3
4.	Product Working Principle.....	7
5.	Installation Guidelines .....	7
6.	Start-up and Commissioning.....	8
7.	Maintenance Procedure .....	9
8.	Available Spares.....	10
9.	Warranty Period .....	11

**PLEASE NOTE** - Throughout this manual this cautionary symbol is used to describe a potential damage or injury that might occur if the safety considerations are overlooked. This symbol denotes **CAUTION, WARNING** or **DANGER**.



## 1. Preface:

This manual is intended for anyone using, commissioning, servicing, or disposing the below mentioned products safely and efficiently.

### Clean Steam Moisture Separator [CSSEP]

**Size: DN 15 (½”), DN 20 (¾”), DN 25 (1”), DN 40 (1 ½”), DN50 (2”), DN80 (3”) and DN100 (4”)**

#### PLEASE NOTE:

Throughout this manual the following cautionary symbol is used to describe a potential damage or injury that might occur if the safety considerations are overlooked.



This symbol denotes **CAUTION, WARNING** or **DANGER**

## 2. Important Safety Notes:

Read this section carefully before installing/operating/maintaining the product. The precautions listed in this manual are provided for personnel and equipment safety. Furthermore, Forbes Marshall accepts no responsibility for accidents or damage occurring as a result of failure to observe these precautions. Note that the product is designed to perform for non-contaminated fluids only. A contamination in the form of chemical, foreign particle etc. can lead to problem with product performance and life of the product.

If these products in compliance with the operating instructions are, properly installed, commissioned, maintained and installed by qualified personnel (refer Section 2.7) the safety operations of these products can be guaranteed. General instructions for proper use of tools and safety of equipments, pipeline and plant construction must also be complied with.

### 2.1 Intended use:

Check if the product is suitable for intended use/ application by referring to the installation and maintenance instructions, name plates and technical information sheets

- i) The product is suitable for use as defined in the technical information sheet. In case the need arises to use the product on any other fluid please contact Forbes Marshall for assistance.
- ii) Check for the suitability in conformance to the limiting conditions specified in technical information sheet of the product.
- iii) The correct installation and direction of fluid flow has to be determined.
- iv) Forbes Marshall products are not intended to resist external stresses, hence necessary precautions to be taken to minimize the same.

### 2.2 Accessibility and Lighting:

Safe accessibility and working conditions are to be ensured prior to working on the product.

### **2.3 Hazardous environment and media:**

The product has to be protected from hazardous environment and check to ensure that no hazardous liquids or gases pass through the product.

### **2.4 Depressurizing of systems and normalizing of temperature:**

Ensure isolation and safety venting of any pressure to the atmospheric pressure. Even if the pressure gauge indicates zero, do not make an assumption that the system has been depressurized. To avoid danger of burns allow temperature to normalize after isolation.

### **2.5 Tools and consumables:**

Ensure you have appropriate tools and / or consumables available before starting the work. Use of original Forbes Marshall replacement parts is recommended.

### **2.6 Protective clothing:**

Consider for the requirement of any protective clothing for you/ or others in the vicinity for protection against hazards of temperature (high or low), chemicals, radiation, dangers to eyes and face, noise and falling objects

### **2.7 Permits to work:**

All work to be carried out under supervision of a competent person. Training should be imparted to operating personnel on correct usage of product as per Installation and Maintenance instruction. "Permit to work" to be complied with (wherever applicable), in case of absence of this system a responsible person should have complete information and knowledge on what work is going on and where required, arrange to have an assistant with his primary goal and responsibility being safety. "Warning Notices" should be posted wherever necessary

### **2.8 Handling:**

There is a risk of injury if heavy products are handled manually. Analyze the risk and use appropriate handling method by taking into consideration the task, individual, the working environment and the load.

### **2.9 Freezing:**

Provision should be made to protect systems which are not self-draining, against frost damage (in environment where they may be exposed to temperatures below freezing point) to be made.

### **2.10 Product Disposal:**

It is necessary to dispose this product only in accordance with local regulations at the authorized, qualified collecting point specified for equipment's and its parts—Please refer the part details mentioned in the material table of this manual. Please follow all waste disposal guidelines (Management & Handling) as published by local governing authorities in India & abroad

### **2.11 Returning products:**

Customers and Stockist are reminded that, when returning products to Forbes Marshall they must provide information on any hazards and the precautions to be taken due to contamination residues or mechanical damage which may present a health, safety or environmental risk.

This information must be provided in writing including Health and Safety data sheets relating to any substances identified as hazardous or potentially hazardous.

### 3. Brief Product Information:

#### 3.1 Description:

Even in the cleanest and best designed clean steam system entrained moisture can still occur, resulting in an unacceptably low dryness fraction, non-compliance of critical sterilisation standards, damage to control valves/instrumentation and a generally low efficiency of the system.

The Forbes Marshall Clean Steam Moisture Separator, CSSEP, has been designed in full accordance with the ASME BPE guide to overcome the issues of removing entrained moisture from clean and pure steam systems.

The CSSEP has a removable baffle plate, allowing the unit to be fully inspected prior to installation and to ease periodic cleaning and derouging.

#### 3.2 Standards:

This product has been designed in accordance with the ASME BPE guide. It also complies with the requirements of the European Pressure Equipment Directive 97/23/EC. All polymers used comply with FDA regulation CFR 21 part 177 section 2600.

#### 3.3 Certification:

This product is available with the following certifications

- EN 10204 3.1 material certifications on request
- Certificate of conformity for internal surface finish
- Certificate of polymers FDA

Note: All certification/ inspection requirements must be stated at the time of order placement.

#### 3.4 Packaging:

Packaging for this product is conducted in a clean environment, segregated from other non stainless steel products and in accordance with ASME BPE for optimum protection and cleanliness. Connections of the product are fitted with protective cap before being sealed in a plastic bag.

#### 3.5 Size and Pipe Connections:

Size	DN 15, 20, 25, 40, 50, 80 and 100
Inlet and Outlet Pipe	Sanitary clamp ASME BPE (Tri-clamp) <sup>®</sup> or extended tube weld ends (ETO) ASMEBPE
Drain	1" ASME BPE for DN15-50 and 2" ASME BPE for DN 80 and 100 (Tri-clamp) <sup>®</sup>
Vent	½" for DN 15-50 and ¾" for DN 80 and 100 ASME BPE (Tri clamp) <sup>®</sup>

#### 3.6 Surface Finish:

Internal 0.5µm (20 micro-inch) maximum as outlined in ASME BPE, with all welds ground and polished

External 1.6µm (63 micro-inch) Ra maximum, with a glassbead blast finish

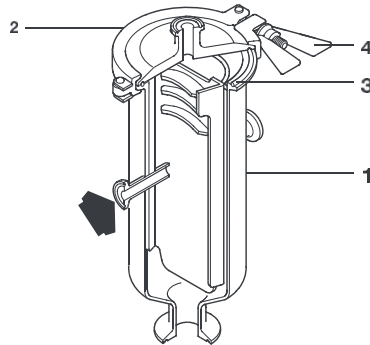

**Figure1: Clean Steam Moisture Separator**

**Material:**

No	Part	Material	Standard
1	Body	Fabricated Stainless Steel	ASTM A 312 316 L ASTM A240 316 L
2	Cover + Baffle	Fabricated Stainless Steel	ASTM A 240 316L ASTM A 240 316L
3	Seal	Viton	
4	Clamp	Stainless Steel	AISI 316

**3.7 Limiting Conditions:**

Body design conditions	PN10
PMA Maximum allowable pressure	10 bar g @ 50°C
Maximum allowable temperature	250°C
Minimum allowable temperature	-10°C
Maximum operating pressure for saturated steam service	7.6 bar g
MO Maximum operating temperature	250°C @ 6.8 bar g
Minimum operating temperature	0°C
Designed for a maximum cold hydraulic test pressure of	15 bar g

**3.8 Operating Range:**

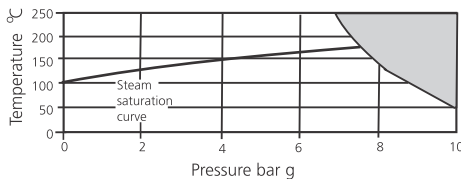

 The product **must not** be used in this region

**Note: For hygienic/sanitary clamp ends the maximum pressure/temperature may be restricted by the gasket or sanitary clamp used. Please consult Forbes Marshall.**

### 3.9 Product Dimension and Drawing:

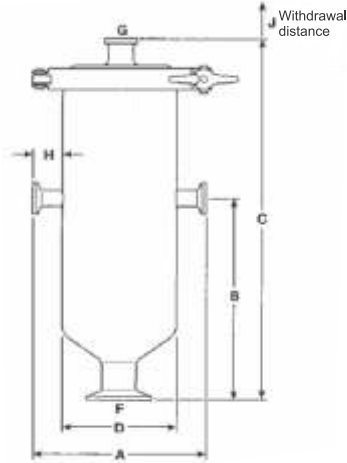

Figure2: CSSEP-Sanitary Clamp End

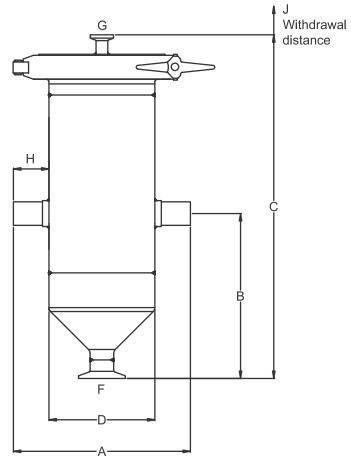

Figure3: CSSEP-Extended Tube Weld End

#### Dimensions, weight and volume (approximate) mm, kg and litres Sanitary Clamp End (Refer fig 2):

Steam inlet / outlet size	A	B	C	D	F (drain)	G (vent)	H	J	Weight	Volume
DN 15	135	158	287	88.9	1"	½"	23	215	3.0	1.2
DN 20	160	177	370	114.3	1"	½"	23	290	5.0	2.5
DN 25	160	177	370	114.3	1"	½"	23	290	5.0	2.5
DN 40	195	210	482	141.3	1"	½"	27	400	9.2	5.5
DN 50	195	210	532	141.3	1"	½"	27	450	10.0	6.3
DN 80	350	305	710	273	2"	¾"	38	570	34	30
DN 100	350	305	855	273	2"	¾"	38	720	40	40

#### Extended Tube Weld Ends (Refer fig 3):

Steam inlet / outlet size	A	B	C	D	F (drain)	G (vent)	H	J	Weight	Volume
DN 15	165	158	287	88.9	1"	½"	38.1	215	3.5	1.2
DN 20	191	177	370	114.3	1"	½"	38.1	290	5.5	2.5
DN 25	191	177	370	114.3	1"	½"	38.1	290	5.5	2.5
DN 40	218	210	482	141.3	1"	½"	38.1	400	10	5.5
DN 50	218	210	532	141.3	1"	½"	38.1	450	10.5	6.3
DN 80	362	305	710	273	2"	¾"	44.5	570	34.5	30
DN 100	375	305	855	273	2"	¾"	51	720	41	40

### 3.10 Steam Sizing Example:

1. Plot point A where the steam pressure and flow rate cross, e.g. 6 bar g/ 500kg/h:  
Draw a horizontal line.
2. Select line size. Any separator curve that is bisected by this line within the shaded area will operate at near 100% efficiency, e.g. 1½" (DN40), point B
3. Ascertain velocity. Line velocity for any size can be determined by dropping a vertical line from this intersection. From point B this line crosses the velocity axis at 23 m/s.

**Note : A velocity correction factor needs to be applied. Please refer to the correction factor table below:**

For this example the velocity correction factor is 1.38 for a 1-1/2" imperial O/D tube therefore the velocity in this example would be 31.74 m/s.

4. Pressure drop. Where the line extended from point B crosses the line C-C, plot a horizontal line. Now drop a vertical line from point A. The point of intersection, D, is the pressure drop across the separator, i.e. about 0.035 bar
5. Separators should be selected on the basis of the best compromise between line size, velocity and pressure drop for each application.

**Note : For larger sizes and alternative, metals and pressure and temperatures that exceed these operating conditions.**

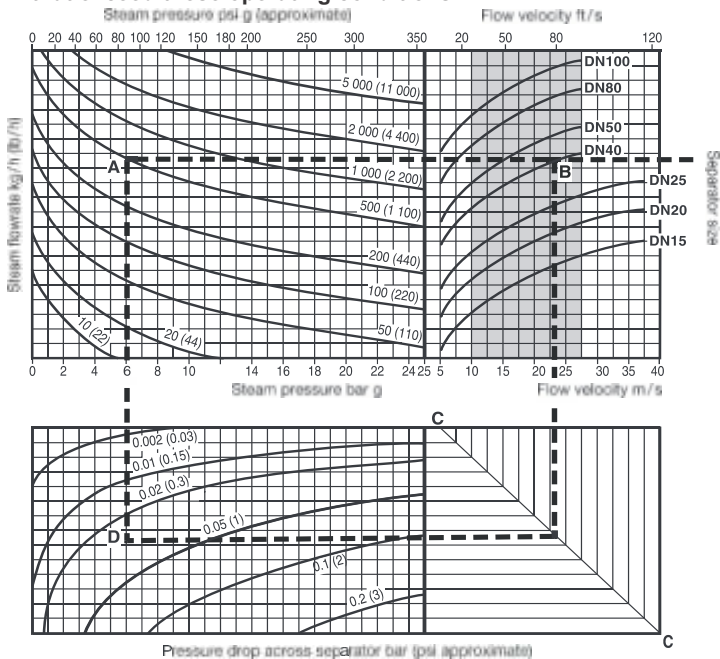

#### Velocity correction factor table:

Separator size (DN)		15	20	25	40	50	80	100
Imperial O/D tubing	I/D (mm)	9.40	15.75	22.10	34.80	47.50	72.90	97.40
	Factor	2.83	1.78	1.45	1.38	1.22	1.14	1.10



#### **4. Operation:**

Clean Steam Moisture Separator are designed to separate small droplets of entrained liquids and then separate them from the gas / vapour flow. The relatively heavy droplets impinge on the internal baffles and are then directed to the separator drain connection and removed from the system using a steam trap, or when used on air or gas distribution system, a liquid drainer.

#### **5. Installation Guidelines:**

**Note: Before actioning any installation observes the ' Important Safety Notes ' in Section 1.**

##### **Important installation note:**

Install in a horizontal pipeline with the drain directly below. To ensure that any separated liquid is drained away quickly, a suitable liquid drainer or steam trap must be connected to the drain.

Referring to the user manual, name plate and technical information sheet ,check that the product is suitable for intended installation.

1. Check materials, pressure and temperature and their maximum values.
2. Determine the correct installation situation and the direction of fluid flow.
3. Remove protective covers from all connections and the protective film from all name-plates, where appropriate, before installation on steam or other high temperature applications.
4. The separators may be lagged if required.
5. Install in a horizontal pipeline with the drain directly below. To ensure that any separated liquid is drained quickly, a suitable liquid drainer or Steam trap must be connected to the drain connection. A float type trap is recommended. For those steam systems where air can be present, air can collect in the upper portion of the separator. In this situation a suitable air vent should be connected to the air vent connection. If an air vent is not being fitted then the connection must have the plastic transit protection plug removed and must have an ASME BPE Tri-Clamp ® fitted.
6. Warnings for Welding:
  - a) Keep your head out of fumes.
  - b) Use enough ventilation , exhaust at the arc, or both to keep fumes and gases away from the breathing zone.
  - c) Wear correct eye, ear and body protection.
  - d) Do not touch live electrical parts.

**Notes: The body must be handled carefully to ensure that the machined surfaces are not damaged.**

## **6. Start-up and Commissioning:**

### **6.1 Flushing of lines:**

As part of pre-installation all fluid handling equipment particularly piping should be thoroughly cleaned of scale and the internal debris which accumulates during construction. This is accomplished by blowing or flushing with air, steam, water and other suitable medium.

Follow these steps to carry out the flushing.

**Note: For a detailed procedure on flushing of lines please visit Forbes Marshall website.**

### **6.2 Commissioning:**

After installation or maintenance ensure that the system is fully functioning by confirming fluid is passing through it.

1. After flushing of lines is complete, ensure that upstream isolation valve is opened.
2. Check for leaks and attend if any.

## 7. Maintenance Guidelines:

**Note:** Before actioning any maintenance Programme observe the 'Important Safety Notes' in Section 2.

Before undertaking any maintenance on the separator it must be isolated from the supply line and return line and any pressure allowed to slowly normalise to atmosphere. The separator should then be allowed to cool.

**Note:** The body and internal parts must be handled carefully to ensure that the machined surfaces are not damaged. Remove sanitary clamps. The cover with baffle plate and seal can then be removed for cleaning or replacement. Reassemble using a new seal. Whenever the cover is disassembled, the seal is to be changed with a new one. Replace and tighten sanitary clamps and put back into service. Check for leaks and relighted as necessary

**Note:** The Safe location bar (Refer to Figure 1) ensures correct orientation of the baffle plate on assembly.

**Note:** Minimum service interval of the seal is 1 year.

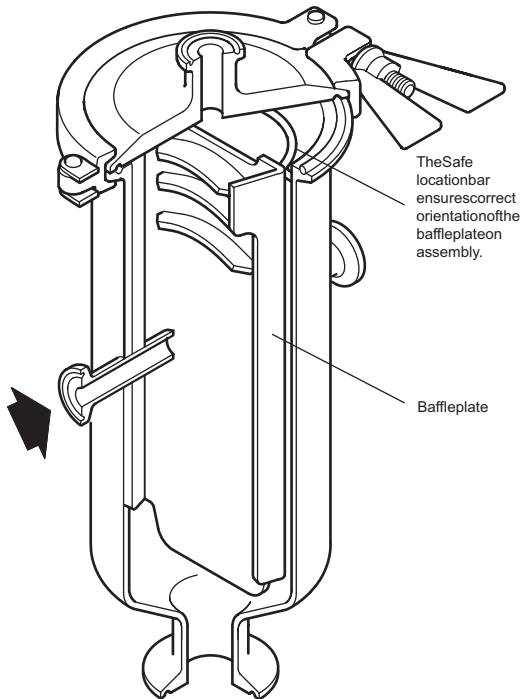
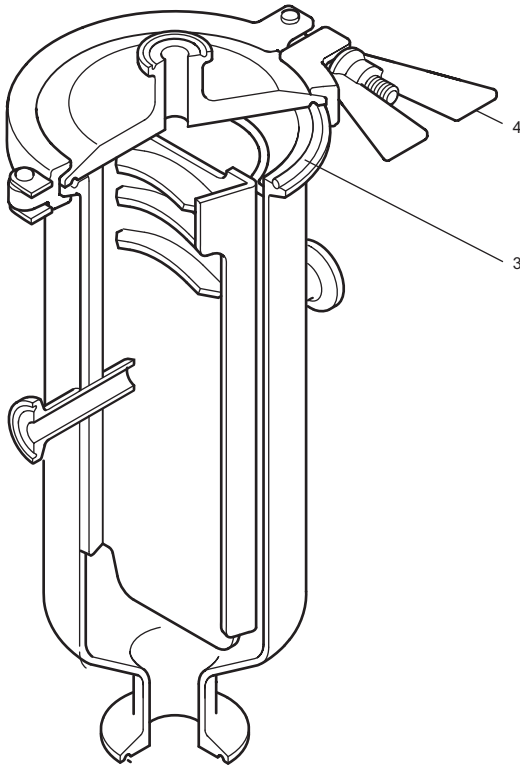

**Figure 4: Correct Orientation of the Baffle Plate on CSSEP**

**8. Available Spares :**

Spare parts are available as indicated in Fig 2. No other parts are supplied as spares.

PART	SIZE	SEAL	CLAMP
SEAL (3) AND CLAMP (4)	DN15	SPARE-15CSSEP-SKIT	SPARE-15CSSEP-CKIT
	DN20&25	SPARE-2025CSSEP-SKIT	SPARE-2025CSSEP-CKIT
	DN40&50	SPARE-4050CSSEP-SKIT	SPARE-4050CSSEP-CKIT
	DN80&100	SPARE-80100CSSEP-SKIT	SPARE-80100CSSEP-CKIT



**Figure 5: Parts available as spares**

**How to order:**

Example: 1 No. DN 50 stainless steel clean steam moisture separator CSSEP with removable baffle plate. Sanitary clamp connections to ASME BPE, internal surface finish of 0.5 mm complete with material to EN 10204 3.1

**How to order spares:**

Always order spares by using the description given in the column headed 'Available spares' and state the size of separator.

**Example: 1 of Seal for a DN15 CSSEP Stainless Steel clean steam moisture separator.**

**9. Warranty Period:**

As per the ordering information and agreement in the contract.



[www.forbesmarshall.com](http://www.forbesmarshall.com)

Forbes Marshall Arca

Codel International

Krohne Marshall

Forbes Vyncke

Forbes Marshall Steam Systems

**A: Forbes Marshall Pvt. Ltd.**

Opp. 106th Milestone, CTS 2220,  
Mumbai-Pune Road, Kasarwadi,  
Pune MH 411034 INDIA

**P:** +91(0)20-68138555

**F:** +91(0)20-68138402

**E:** [ccmidc@forbesmarshall.com](mailto:ccmidc@forbesmarshall.com)

**Forbes Marshall International Pte. Ltd.**

16A, Tuas Avenue 1,  
#05-21, JTC Space @Tuas  
Singapore - 639533

**P:** +65 6219 3890

**CIN No:** U28996PN1985PTC037806