

EverSense for Paper Machines



The average industry specific steam consumption (SSC) varies by 5-10% and the condensate recovery factor (CRF) varies between 70-75% for paper machines. We can reduce the bands of variation significantly, reducing SSC by 0.1-0.3 per ton of paper and obtaining CRF >85%.

In today's dynamic and competitive landscape, where energy costs continue to rise, maintaining an efficient steam system is imperative. An increase in SSC and a drop in CRF leads to incremental fuel and fresh water consumption.

SSC and CRF variation causes include:

- Correct design of the paper drying system
- Uptime of components and control loops
- Paper quality
- Paper type
- Machine speed
- Operator experience

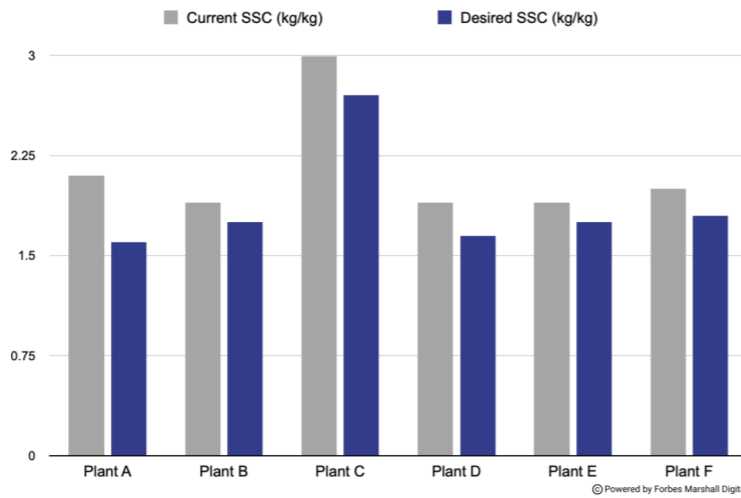

We provide actionable insights

Proactive Issue Resolution

Monitoring critical parameters gives insight into the steam condensate system, uptime of components and control loops, operating procedures, optimum set-point prediction of dryer group steam pressure variations for paper grade, paper quality, paper type, machine speed, heat transfer issues, and inappropriate settings. Our regular reports cover key insights for your plant.

Operational Efficiency

We help establish standard operating procedures (SOPs) and provide training to operators on best practices. We provide a section wise or paper wise paper machine performance benchmark, a log book and failure mode effect and analysis for customers.

Backed by our wide reach and expertise

Our team of sales and service engineers, based in 18 countries, have experience of over 30 industry segments globally. These specialists visit plants daily, understanding and addressing real needs. And now, you have 24x7 access to this expertise through both, digital connects and site visits.



Delivering Benefits



Reliability
Maintaining >95% uptime.



Productivity
Increasing productivity and bettering product quality.



Fuel Savings
Lowering specific steam consumption and improving condensate recovery.



Sustainability
Reducing fuel consumption, and thereby reducing carbon emissions.

Trap Based System

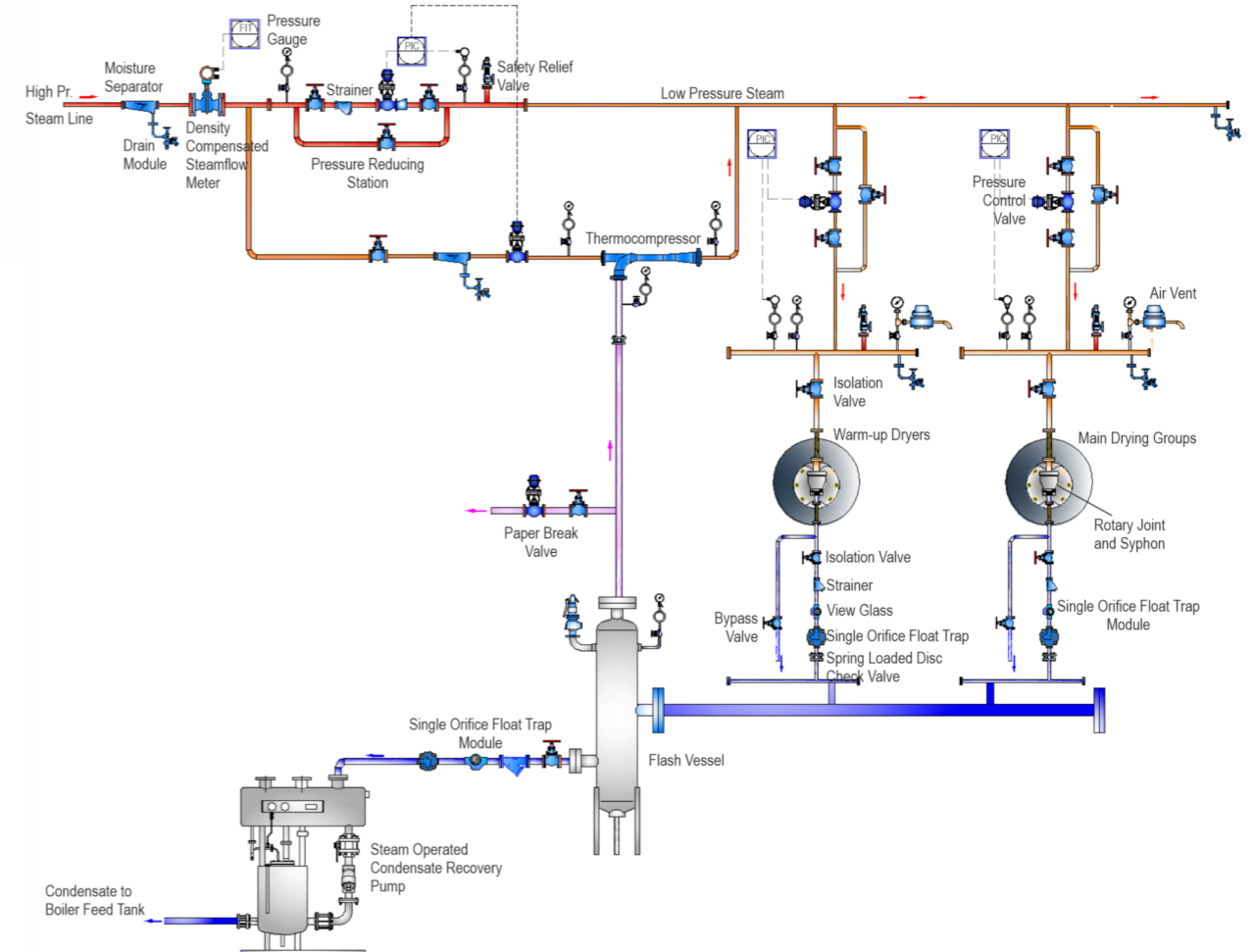

Energising Businesses and Communities Worldwide



A Multinational with Indian Roots

19	Countries
37	Offices Worldwide
18	Distribution Centres
500	Sales and Services Engineers
8,000	Customers Worldwide

World Class Technology from World Class Facilities



Enabling Results



Process Efficiency



Energy Efficiency



Optimum Productivity



Improved Asset Uptime



Environmental Responsibility



Safety and Regulatory Compliance



www.forbesmarshall.com

Forbes Marshall Arca

Codel International

Krohne Marshall

Forbes Vyncke

Forbes Marshall Steam Systems

A: Forbes Marshall Pvt. Ltd.

Opp. 106th Milestone, CTS 2220, Mumbai-Pune Road, Kasarwadi, Pune MH 411034 INDIA

P: +91(0)20-68138555

F: +91(0)20-68138402

E: beyondconnectivity@forbesmarshall.com

CIN No: U28996PN1985PTC037806

© All rights reserved. Any reproduction or distribution in part or as a whole without written permission of Forbes Marshall Pvt Ltd, its associate companies or its subsidiaries ("FM Group") is prohibited. Information, designs or specifications in this document are subject to change without notice. Responsibility for suitability, selection, installation, use, operation or maintenance of the product(s) rests solely with the purchaser and/or user. The contents of this document are presented for informational purposes only. FM Group disclaims liabilities or losses that may be incurred as a consequence of the use of this information.



Scan the QR code to enquire