

IJ-Flange

Insulation Jacket For DN 15 and DN 20 Flange

Description

Forbes Marshall Insulation Jackets are used for preventing any heat energy losses from flanged joints. The insulation jackets for flanges are available in one piece and ready to mount condition. It can be removed and reinstalled for maintenance

Available Versions

Available in low temperature versions with velcro fitting suitable for all types of flanges from DN 15 to DN 80.

Limiting Conditions

Maximum metal surface temperature : 220°C

How to Order

Example: 1No. insulation jacket for flange size DN 50

Installation

Once the flanges are installed the insulation jacket can be fixed as follows

- Place the jacket on to the pair of flanges.
- Slide the jacket up to cover the flanged connection and pull the Velcro flap into secure position.
- Wrap front and back of jacket around the flanges and secure fully by using the velcro flap. Finally pull and tie the cords to minimise any gap that would allow air to flow or allow ingress of water.

Removal

Before removing the jacket check if the flanges are in service. If they are then metal surface will be hot enough to burn. So suitable protective gloves, apron etc should be worn. Removal is reverse process to the above..

Handling

When the jackets are new insulation material is fully enclosed within the inner and outer face and retained by stitching. In this condition no special protective clothing is required. However the inner and outer face becomes unstitched or damaged, so as to expose the insulation material, then suitable protective clothing (e.g. Gloves, safety glasses, face mask and overall) should be worn while handling.

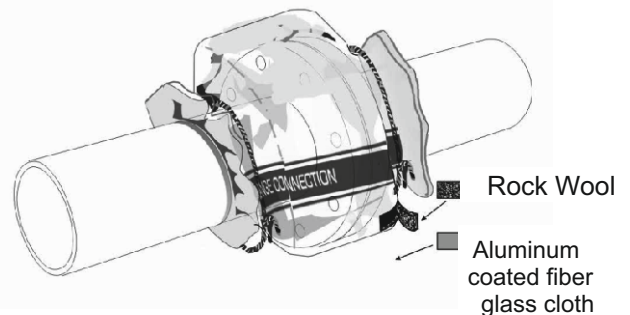

Disposal

This product is not recyclable and is non-combustible. For disposal purpose consider the product to be mineral fibre and dispose off in accordance with local regulations.



Forbes Marshall
Krohne Marshall
Forbes Marshall Arca
Codel International
Forbes Solar
Forbes Vyncke
Forbes Marshall Steam Systems

Opp 106th Milestone
Bombay Poona Road
Kasarwadi, Pune - 411 034. INDIA
Tel : 91(0)20-27145595, 39858555
Fax : 91(0)20-27147413

Email : seg@forbesmarshall.com, ccmidc@forbesmarshall.com

© All rights reserved. Any reproduction or distribution in part or as a whole without written permission of Forbes Marshall Pvt Ltd, its associate companies or its subsidiaries ("FM Group") is prohibited.

Information, designs or specifications in this document are subject to change without notice. Responsibility for suitability, selection, installation, use, operation or maintenance of the product(s) rests solely with the purchaser and/or user. The contents of this document are presented for informational purposes only. FM Group disclaims liabilities or losses that may be incurred as a consequence of the use of this information.

B-85, Phase II, Chakan Indl Area
Sawardari, Chakan, Tal. Khed
Dist. Pune - 410 501. INDIA
Tel : 91(0)2135-393400

A-34/35, MIDC H Block
Pimpri, Pune - 411 018. INDIA.
Tel : 91(0)20-27442020, 39851199
Fax : 91(0)20-27442040

CIN No.: U28996PN1985PTC037806
www.forbesmarshall.com