

FMTD722-M

Forbes Marshall Thermodynamic Trap

Description

The Forbes Marshall Thermodynamic Trap, FMTD722-M, is a maintainable high pressure thermodynamic steam trap with an integral strainer and a replaceable seat for ease of maintenance. It has low capacity and is specifically designed for superheated applications up to 250 bar g.

Sizes and Pipeline Connections

DN15 / DN20 and DN25 butt weld ends to suit SCH160 pipe.

DN15 and DN20 socket weldable ends to ASME (ANSI). B 16.11 Class 6000.

Available with IBR certificate.

Note : Available with ANSI 600 and ANSI 1500 flanges on request

Limiting Conditions

Note : if the product is used at pressure above 170 bar barg we recommend regular inspection of the seat.

Body design conditions	PN250
PMA Maximum allowable pressure	250 barg @300°C
TMA Maximum allowable temperature	550°C @ 80 barg
Minimum allowable temperature	-29°C
PMO Maximum operating pressure	220 barg @374°C
TMO Maximum operating Temperature	550°C @ 80 barg
Minimum operating temperature	0°C
PMOB Maximum operating back pressure should not exceed 50% of upstream pressure	
Minimum operating differential temperature	8 barg
Designed for a maximum cold hydraulic test pressure	375 barg

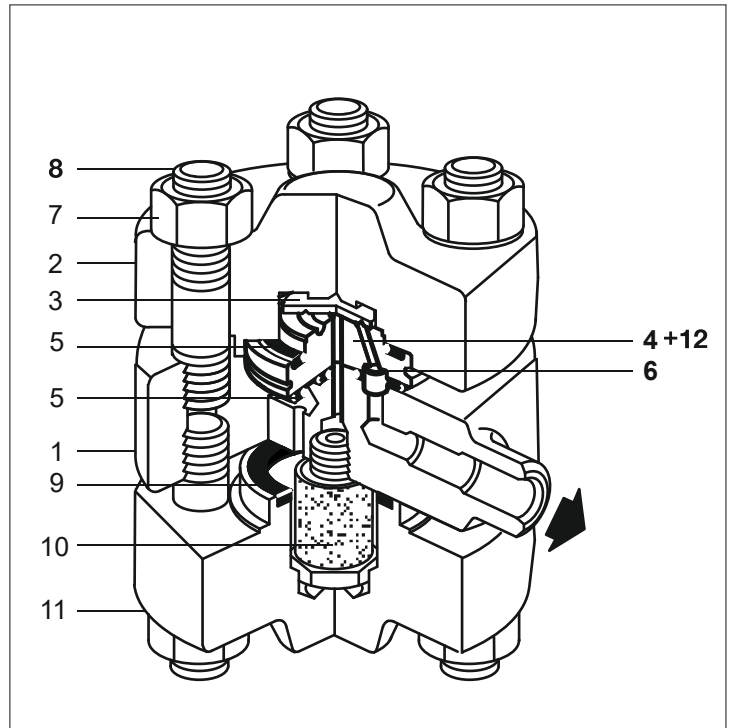

Material

No.	Part	Material	Standard
1	Body	Alloy Steel	ASTM A182F 22
2	Top Cover	Alloy Steel	ASTM A182 F 22
3	Disc	Steel	AISI D2
4	Seat	Steel	AISI D2
5	Top Cover Gasket	Spirally wound SS with exfoliated graphite filler	(ASME B16-20)
6	Inner seat Gasket	SS with exfoliated graphite filler	
7	Cover Nuts	Steel	ASTM A194 Gr. 4
8	Cover Studs	Steel	ASTM A193 Gr. B.16
9	Bottom Cover Gasket	SS with exfoliated graphite filler	(ASME B16-20)
10	Strainer Screen Assembly	Stainless Steel	BS 970 304 515/ sintered stainless (ASTM A276-304)
11	Bottom Cover	Alloy Steel	ASTM A182 F22
12	Ferrule	Stainless Steel	

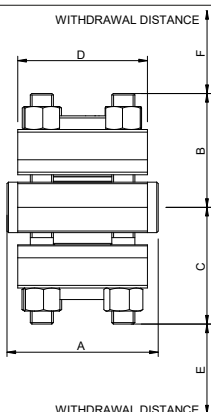

Size	DN 15	DN20	DN25
A	105	105	105
B	80	80	80
C	80	80	80
D	90	90	90
E	55	55	55
F	55	55	55
Weight	8 Kg	8 Kg	8 Kg

How to Order

Example : 1 No. Forbes Marshall Thermodynamic Trap, FMTD722-M, with maintainable seat, butt weld ends to suit schedule 160 pipe.

Operating Range

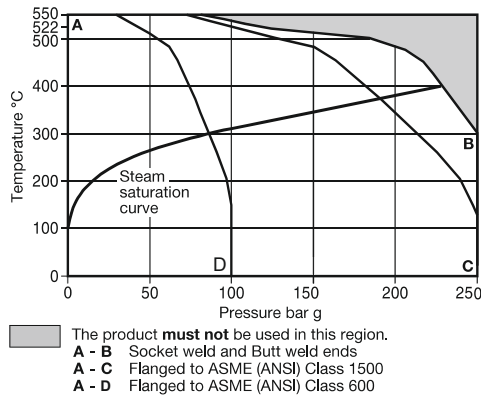

Safety Information, Installation and Maintenance

For full details see the installation and maintenance instruction supplied with the product.

Installation Note

The FMTD722-M is designed for installation with the nameplate on top, in a horizontal pipeline. For ease of maintenance, consideration should be given to fitting isolation valves upstream and downstream of the steam trap.

After 24 hours in service the cover nuts should be checked for tightness.

Capacity Chart (in accordance with ISO 7842)

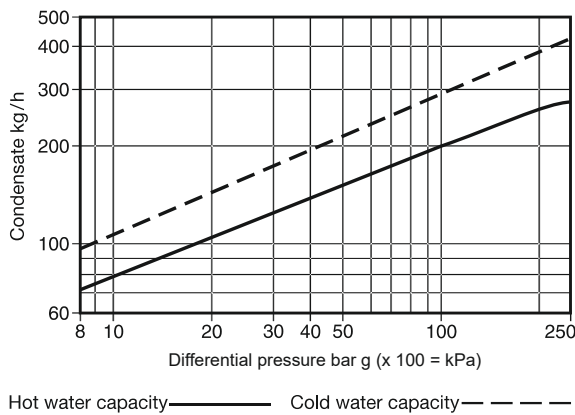

Spare Parts

The spares available are shown in solid outline. Parts drawn in broken line are not supplied as spares.

Available spares

Set of cover studs and nuts	8 and 7 (pack of 8)
Strainer screen and gasket	10, 9
Set of gaskets	5 (2 nos), 6, 9 (Pack of 3)
Set of internals	3, 5 (2 Nos.), 6, 9, 10, 4+12

Recommended tightening torques

Item	Part	Or mm	Nm
10	Spool	22 A/F	25-35
8	Stud	M 16	85-90
7	Nut	23 A/F M16	160-180

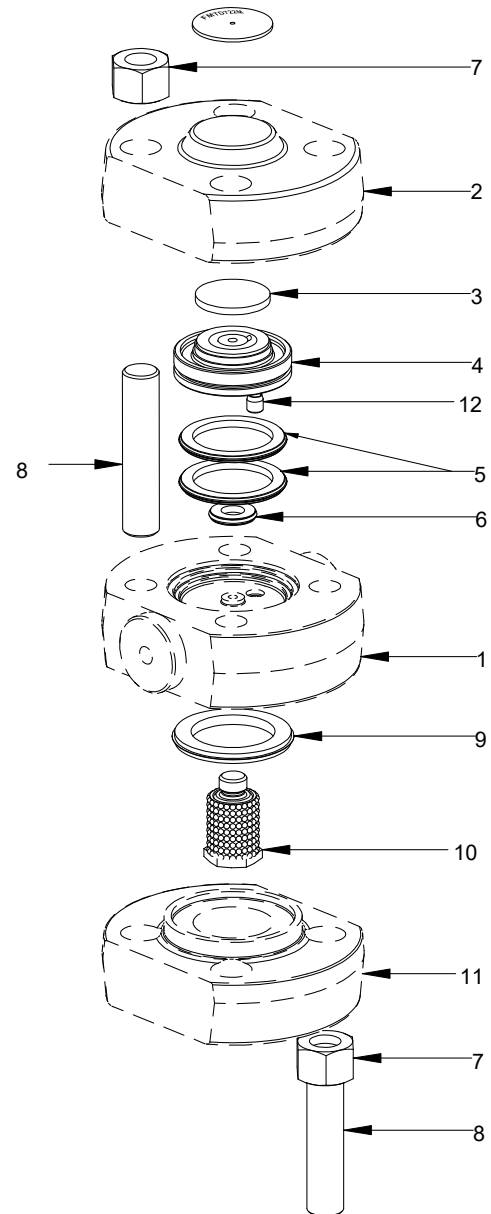

www.forbesmarshall.com

Forbes Marshall Arca

Codel International

Krohne Marshall

Forbes Vyncke

Forbes Marshall Steam Systems

A: Forbes Marshall Pvt. Ltd.
Opp. 106th Milestone, CTS 2220,
Mumbai-Pune Road, Kasarwadi,
Pune MH 411034 INDIA

P: +91(0)20-68138555

F: +91(0)20-68138402

E: ccmidc@forbesmarshall.com

© All rights reserved. Any reproduction or distribution in part or as a whole without written permission of Forbes Marshall Pvt Ltd, its associate companies or its subsidiaries ("FM Group") is prohibited.

Information, designs or specifications in this document are subject to change without notice. Responsibility for suitability, selection, installation, use, operation or maintenance of the product(s) rests solely with the purchaser and/or user. The contents of this document are presented for informational purposes only. FM Group disclaims liabilities or losses that may be incurred as a consequence of the use of this information.

Forbes Marshall International Pte. Ltd.

16A, Tuas Avenue 1,
#05-21, JTC Space @Tuas
Singapore - 639533

P: +65 6219 3890

CIN No: U28996PN1985PTC037806

DOC# FMSS/0824/TIS-FMTD76-MR4