

# FMPAV

## Forbes Marshall Piston Actuated Valve

### Description

The Forbes Marshall Piston Actuated Valve, FMPAV, is a 2-port pneumatically actuated on/off stainless steel valve for use on steam, water, air, oil and gases. A pneumatic signal acts on the actuator piston to open or close the valve with a spring return action. The valve plug has a PTFE soft seal to provide a tight shut off. A valve position indicator is included on standard and flow regulator models.

### NC (Normally Closed)

These valves are designed for flow over the seat (port 1 to 2)  
Caution: Not recommended for water hammer prevention.

### NO (Normally Open)

These valves are designed for flow under the seat (port 2 to 1) Can be used to prevent water hammer on valve closure in liquid applications

### BD (Bi-directional Normally Closed)

These valves are designed for special applications that require flow in both directions and incorporates an anti-waterhammer design for liquid applications flowing under the seat (port 2 to 1)

**Note:** To help prevent the possibility of water hammer on liquid applications flowing over the seat (port 1 to 2) the pressure should not exceed 1 bar g.

### Material

No.	Part	Material	Standard
1.	Body	Stainless Steel	AISI 316 L
2.	Bonnet	Stainless Steel	AISI 316 L
3.	Plug	Stainless Steel	AISI 316 L
4.	Plug Seal	PTFE	-
5.	Valve Stem	Stainless Steel	AISI 316 L
6.	Stem seal	PTFE chevrons	-
*7.	Stem O ring	Viton	-
8.	Actuator housing	Glass filled polyamide	-
9.	Piston	Glass filled polyamide	-
10.	Piston lip seal	Nitrile	-
#11.	Gasket	PTFE	-
#12.	"O" ring	Viton	-

\* Not Shown

# Sanitary tube ends ASME BPE: Aramide NBR Gasket

### Normally Closed

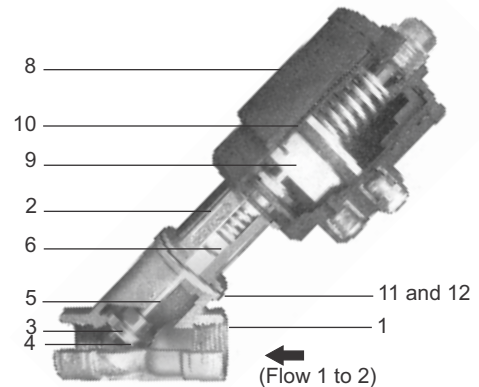

### Normally Open

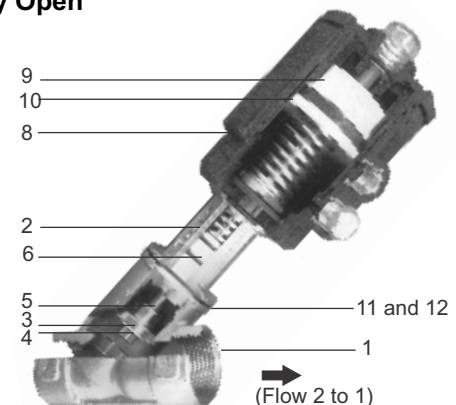

### Bi-Directional (Normally Closed)

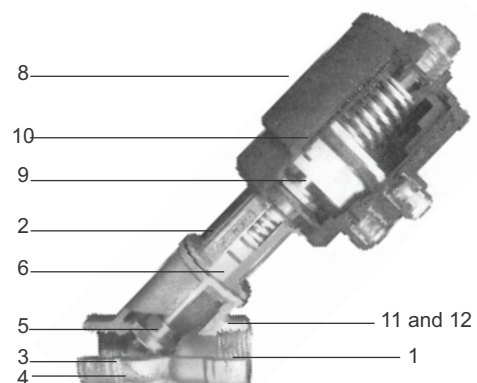

Available Range : Sizes DN 15,20,25,40 and 50 Sizes are available with 63 mm Actuator

Valve Action	Screwed			Butt Weld to ANSI B 36.10	Socket Weld ANSI B 36.10	*Sanitary Clamp to ISO 2852	Flanged to ANSI 150
	BSPT	BSP	NPT				
NC-Normally Closed (Flow over seat)	FMPAV-NC-A	FMPAV-NC-C	FMPAV-NC-B	FMPAV-NC-W	FMPAV-NC-I	FMPAV-NC-S	FMPAV-NC-Q
NO-Normally Open (Flow under seat)	FMPAV-NO-A	FMPAV-NC-C	FMPAV-NO-B	FMPAV-NO-W	FMPAV-NO-I	FMPAV-NO-S	FMPAV-NO-Q
BD-Bi-directional Normally Closed (Flow under or over seat)	FMPAV-BD-A	FMPAV-NC-C	FMPAV-BD-B	FMPAV-BD-W	FMPAV-BD-I	FMPAV-BD-S	FMPAV-BD-Q

\*All options available with DN 40 and 50 FMPAV 90.

\*Note: Clamp ends are not included.

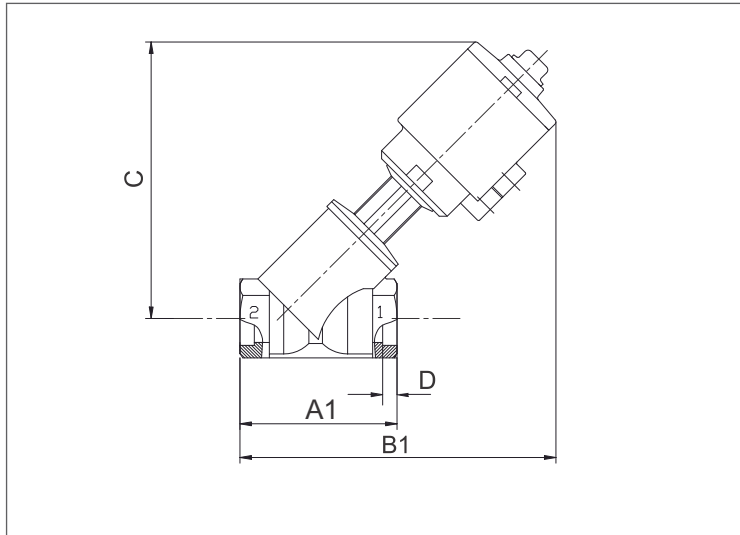

**Dimensions / weights (approximate) in mm and Kg FMPAV-screwed, Butt & socket weld ends**

Valve Size DN	Actuator bore	A1	B1	C	D	Weight
15	63	65	186	155	5	1.2*
20	63	75	192	170	7	1.3*
25	63	90	206	180	8	1.5*
40	63	120	224	198	12	2.4*
50	63	150	243	202	16	2.9*
40	90	120	249	218	12	2.9*
50	90	150	269	228	16	3.7*

\*Plus 0.2 kg for travel switch or flow regulator option  
Dimensions "D" is the socket weld connections only

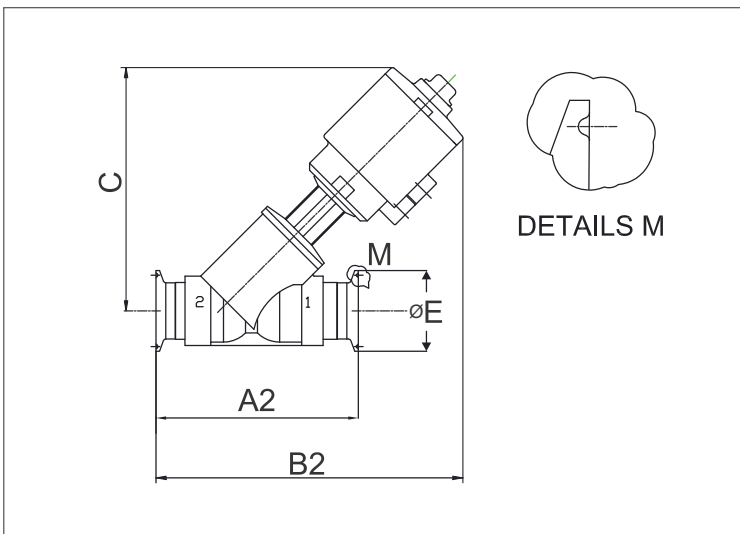

**FMPAV-Sanitary clamp ends ISO:2852 #**

Valve Size DN	Actuator bore	A2	B2	C	ØE	Weight
15	63	102	205	165	34	1.3*
20	63	114	212	170	34	1.5*
25	63	129	226	180	50.5	1.8*
40	63	159	243	193	64	2.8*
50	63	190	263	202	64	3.6*
40	90	159	269	218	64	3.3*
50	90	190	288	228	64	4.4*

\*Plus 0.2 kg for travel switch or flow regulator option  
# For ASME BPE Sanitary Clamp ends please contact FORBES MARSHALL

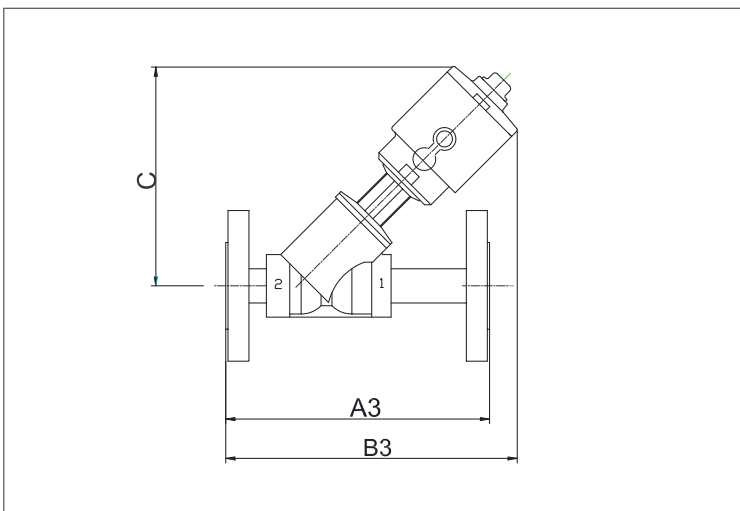

**FMPAV-ANSI 150 FLANGED ENDS**

Valve Size DN	Actuator bore	A3	B3	C	Weight
15	63	140	191	165	2.3*
20	63	152	200	170	2.7*
25	63	165	213	180	3.5*
40	63	203	232	193	6.2*
50	63	229	250	202	8.4*
40	90	203	258	218	6.7*
50	90	229	276	228	9.2*

\*Plus 0.2 kg for travel switch or flow regulator option

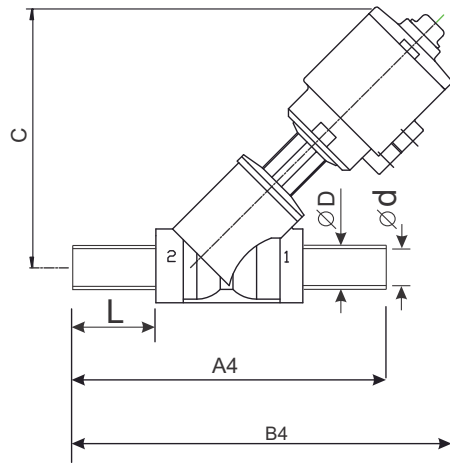

### FMPAV-Sanitary tube ends ASME BPE

Valve Size DN	Actuator bore	A4	B4	C	L	ØD	Ød	Weight
15	63	132	213	165	38	12.7	9.4	1.5*
20	63	140	218	170	38	19.05	15.75	1.7*
25	63	150	229	180	38	25.4	22.1	1.9*
40	63	176	245	193	38	38.1	34.8	3.4*
50	63	187	255	202	38	50.8	47.5	4.3*
40	90	176	270	218	38	38.1	34.8	3.9*
50	90	187	280	227	38	50.8	47.5	5.1*

\*Plus 0.2 kg for travel switch or flow regulator option

### Options

#### Flow Regulator

Limits valve lift to regulate maximum flow.

#### Pilot Solenoids

3/2 way solenoid valve for 230 VAC, 110 VAC and 24 VAC and 24 VDC

#### Travel Switch

Relays an electrical signal to indicate open or closed position of the valve.

### Technical Details

Leakage	PTFE soft seal	ANSI Class VI
Flow Characteristics	Fast opening	On/off
Flow direction	NC flow over seat NO Flow underseat BD Flow overseat Flow underseat	Port 1 to 2 Port 2 to 1 Port 1 to 2 Port 2 to 1
Pilot media for	Air/water*	+60°C (140°F) *(water-a suitable drain line should be provided)max
Actuator housing rotation (Clockwise-see sticker on actuator)	360°	
Actuator size 63mm (2½") diameter 90mm (3½") diameter	Pilot connection ¼"BSP ¼"BSP	Max. pilot pressure 10 bar g (145 psi g) 8 bar g (116 psi g)

### Kv Values

Size	DN15	DN20	Dn25	DN 40	DN 50
Kvs	4.2	7.8	18.6	42	51.6

For conversion Cv (UK)=Kv x 0.97 Cv (US)=1.17

### Operating range

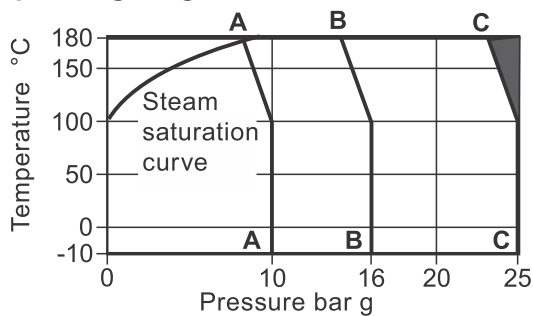

- A - A PN10
- B - B PN16 and ASME 150
- C - C PN25

The product **must not** be used in this region or beyond the body design conditions quoted in the table below as damage to the internals will occur.

### Limiting Conditions

Body design conditions	DN 15 to 25	PN 25
Screwed, butt and socket weld	DN 40 and 50	PN 16
Flanged ANSI	DN 15-50	Class 150
Sanitary Clamp and tube compatible connections	DN 15-50	PN 10
Maximum design temperature	180°C	
Minimum design temperature	-10°C	
Maximum saturated steam pressure	9 bar g	
Maximum differential pressure	See table below	

### End Connections

Screwed, Butt and Socket Weld	
A-A Max. operating pressure on saturated steam	9 bar g (130 psi g)
B-B Max. operating pressure	DN 40 and DN50- 16 bar g (232 psi g)
C-C Max. operating pressure	DN 15 to DN25 - 25 bar g (360 psi g)
Flanged ANSI	DN 15-50, Class 150
Sanitary Clamp and Tube Ends	

### Differential pressure for FMPAV-NC (Normally closed)

Valve Size DN	Actuator diameter	Flow Direction (1 to 2)	*Maximum differential pressure (bar g)	Pilot pressure min. (bar g)	Pilot pressure max. (bar g)
15	63	Over seat	20	1.5	10
20	63	Over seat	20	1.5	10
25	63	Over seat	20	1.5	10
40	63	Over seat	16	2.8	10
50	63	Over seat	11	2.8	10
40	90	Over seat	16	2.7	8
50	90	Over seat	16	2.7	8

**Note:** Maximum differential pressure with saturated steam is 9 bar g (180°C)

### Differential pressure for FMPAV-NC (Normally open)

Valve Size DN	Actuator diameter	Flow Direction (2 to 1)	*Maximum differential pressure (bar g)	Pilot pressure min. (bar g)	Pilot pressure max. (bar g)
15	63	Under seat	16	1.5	10
20	63	Under seat	16	1.5	10
25	63	Under seat	16	1.5	10
40	63	Under seat	16	1.5	10
50	63	Under seat	12	1.5	10
40	90	Under seat	16	1.2	8
50	90	Under seat	16	1.2	8

**Note:** Maximum differential pressure with saturated steam is 9 bar g (180°C)

### Differential Pressure for FMPAV-BD (Bi-directional normally closed)

Valve Size DN	Actuator diameter	Flow Direction (1 to 2)	*Maximum differential pressure (bar g)	Flow direction (2 to 1)	Maximum differential pressure (bar g)	Pilot pressure min. (bar g)	Max (bar g)
15	63	Over Seat	16	Under seat	16	3.8	10
20	63	Over Seat	16	Under seat	16	3.8	10
25	63	Over Seat	16	Under seat	11	3.8	10
40	63	Over Seat	12	Under seat	4	3.8	10
50	63	Over Seat	8	Under seat	2.5	3.8	10
40	90	Over Seat	16	Under seat	8.5	3.1	8
50	90	Over Seat	16	Under seat	6	3.1	8

\*Maximum differential pressure for all media pressures

**Note:** Maximum differential pressure with saturated steam is 9 bar g (180°C)

**Pilot / Media Pressure Relationship**  
**FMPAV (NC) - flow over seat (1 to 2)**

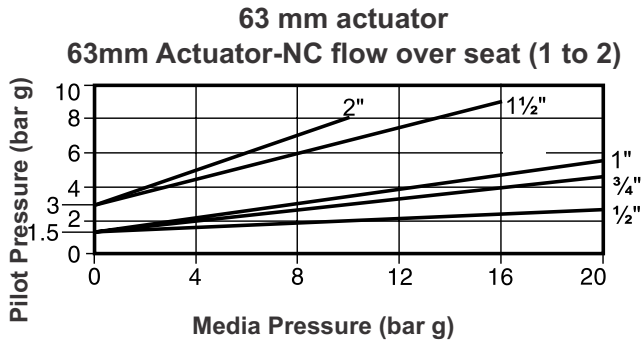

**90 mm actuator**

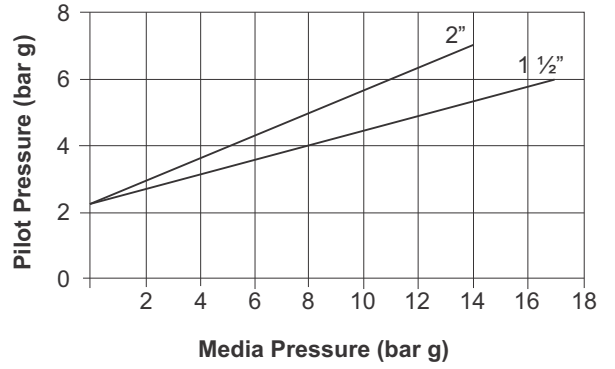

**FMPAV (NO) - flow under seat (2 to 1)**

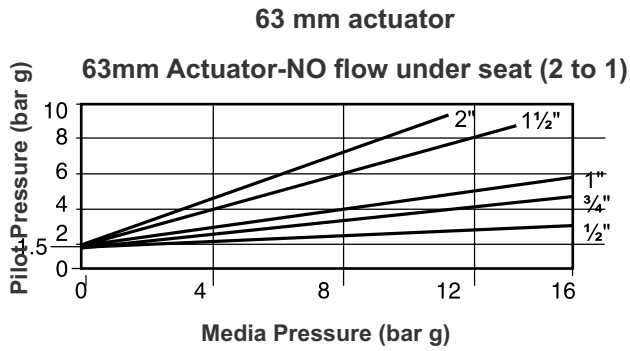

**90 mm actuator**

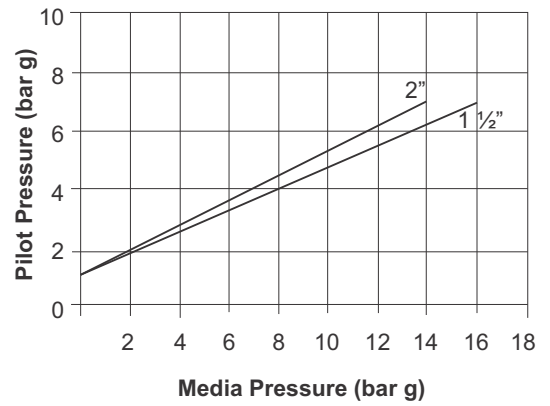

**FMPAV (BD) - flow over seat (1 to 2)**

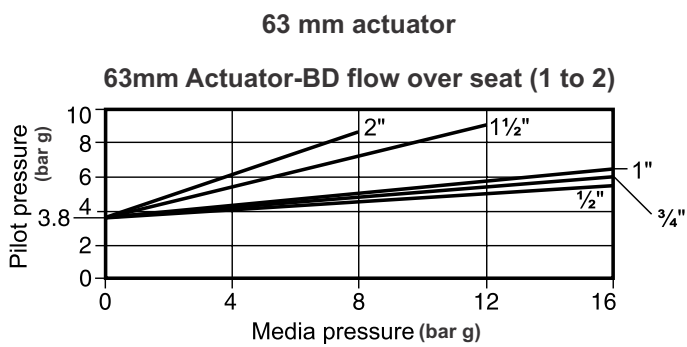

**90 mm actuator**

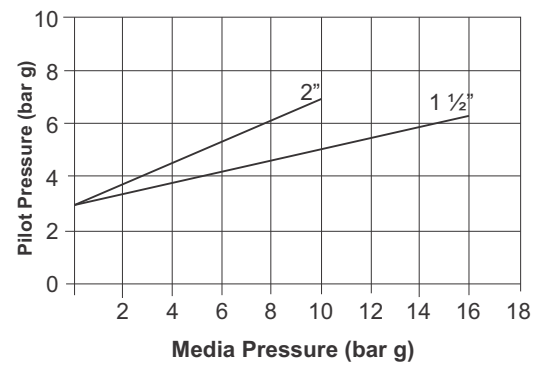

## Installation

The valve can be installed in any position with the direction of flow as indicated on the inlet / outlet ports by the connection numbers 1 to 2 for NC, 2 to 1 for NO and bi-directional for BD. To simplify mounting of solenoid valves the actuator can be rotated 360°(clockwise).

**Note:** Do not rotate actuator in anti-clockwise direction.

The pipework should be supported to prevent the valve body being stressed.

Installation and Maintenance instructions are given in the user manual provided with the valve.

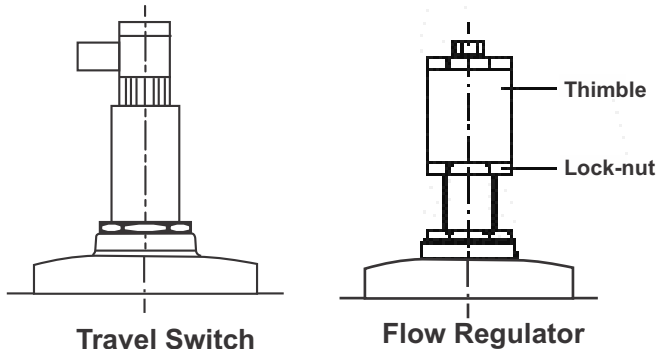

## Spare Parts

A seal kit is available for all valve and actuator size comprising: piston lip seal, actuator stem "O" ring, plug soft seal (PTFE) body seal and "O" ring##

### How to Order Spares

Always order spares by specifying the valve size type and date code (given on actuator calendar i.e. 906= month September, year 2006)

**Example:** Seal kit 025 FMPAV as per part no mentioned in User Manual.

## How to Order Valve Selection Guide

025	FMPAV	63	NC	-	A	S	N	E
1	2	3	4		5	6	7	8

1.Valve Size (DN) : 15, 20, 25, 40, 50

2.Valve Type : FMPAV Forbes Marshall Piston Actuated Valve

3.Actuator Size : 63 mm diameter / 90 mm diameter

4.Valve Position : NC Normally closed  
NO Normally open  
BD Bi directional

5.Connection : A-BSPT (screwed)  
B-NPT (screwed)  
C-BSP  
W-Butt weld

**Note :** Pipeline connection as per ANSI B 36.10  
I-Socket Weld

**Note :** Pipeline connections as per ANSI B 36.10  
S-Sanitary ISO2852

**Note :** Clamp and Clamp gaskets are not included  
X-Sanitary Tube ends t  
ASME BPE  
Q- Flanged ANSI 150

6.Options : S - Standard version with visual indicator.  
F - Flow regulator  
R - REED switch 250V, 1 amp, 1 change over type standard

7.N : NON – IBR

8.Blank : without solenoid valve

"E" Standard Solenoid valve, 3/2 way, 230V, with bulkhead connector. Solenoid valve with 110, 24V AC and 24V DC as option.



www.forbesmarshall.com

Forbes Marshall Arca

Codel International

Krohne Marshall

Forbes Vyncke

Forbes Marshall Steam Systems

**A: Forbes Marshall Pvt. Ltd.**  
Opp. 106th Milestone, CTS 2220,  
Mumbai-Pune Road, Kasarwadi,  
Pune MH 411034 INDIA

**P:** +91(0)20-68138555

**F:** +91(0)20-68138402

**E:** ccmidc@forbesmarshall.com

© All rights reserved. Any reproduction or distribution in part or as a whole without written permission of Forbes Marshall Pvt Ltd, its associate companies or its subsidiaries ("FM Group") is prohibited.

Information, designs or specifications in this document are subject to change without notice. Responsibility for suitability, selection, installation, use, operation or maintenance of the product(s) rests solely with the purchaser and/or user. The contents of this document are presented for informational purposes only. FM Group disclaims liabilities or losses that may be incurred as a consequence of the use of this information.

**Forbes Marshall International Pte. Ltd.**  
16A, Tuas Avenue 1,  
#05-21, JTC Space @Tuas  
Singapore - 639533

**P:** +65 6219 3890

**CIN No:** U28996PN1985PTC037806