

# FMBT50

## Forbes Marshall Bucket Trap

### Description

The Forbes Marshall Bucket Trap FMBT50, is designed to fit into horizontal pipelines. It is maintainable in line and is complete with integral strainer screen.

### Size and End Connections

DN 15, DN20, and DN25  
Screwed BSPT/NPT  
Socket weldable ends

### Limiting Conditions

Body design conditions	42 barg
PMA Maximum Allowable Pressure	32 barg
TMA Maximum Allowable Temperature	300°C
Maximum Operating Pressure	32 barg
Maximum Operating Temperature	300°C
Cold Hydraulic Test pressure	48 barg
Minimum Operating Temperature	0°C

Note : Maximum operating conditions depend upon orifice size.

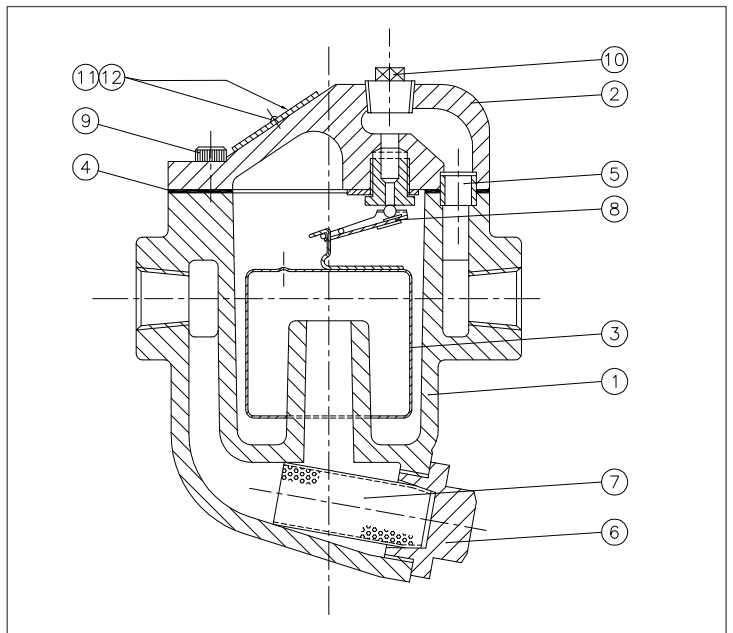
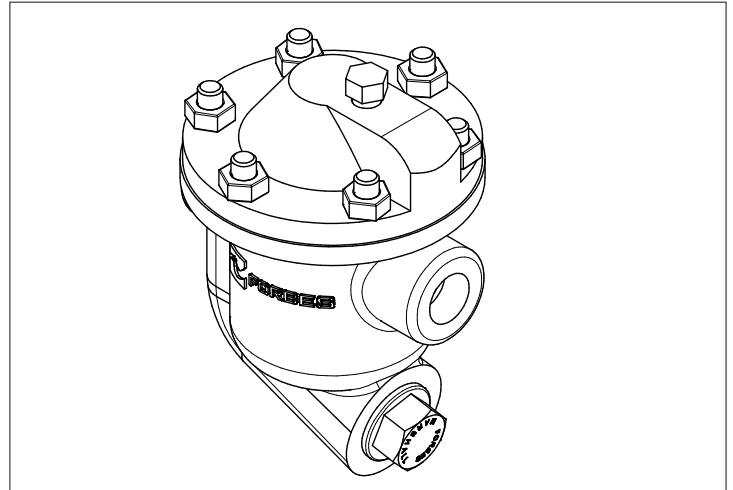

### DPMX - maximum differential pressure

DN 15	DN 20	DN 25	$\Delta$ PMX (bar) g
FMBT 50/4	FMBT 50/5	FMBT 50/5	32.0
FMBT 50/5	FMBT 50/6	FMBT 50/6	20.0
FMBT 50/6	FMBT 50/7	FMBT 50/8	12.0
FMBT 50/7	FMBT 50/8	FMBT 50/10	8.5
FMBT 50/8	FMBT 50/10	FMBT 50/12	4.0

### Operating Range

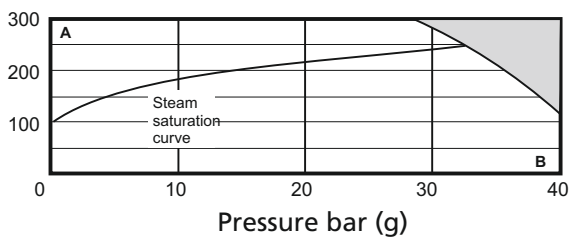

 The Product must not be used in this region  
A-B Screwed socket weld

### Material

S.No.	Description	Material	Standard
1	Body	Cast Steel	ASTM A216 Gr WCB
2	Cover	Cast Steel	ASTM A216 Gr WCB
3	Bucket Assembly	Stainless Steel	S.S. 304
4	Cover Gasket	SS Exfoliated Graphite	
5	Ferrule	Stainless Steel	S.S. 304
6	Strainer Cap	Stainless Steel	BS 3146 ANC2
7	Strainer Screen	Stainless Steel	S.S. 304
8	Valve and Seat Assly. 10 BAR Valve and Seat Assly. 8.5 BAR Valve and Seat Assly. 4.0 BAR	Stainless Steel	S.S. 304
9	Socket HD. CAP SCREW	Alloy Steel	ASTM A 193 Gr B7
10	Plug 3/8" BSPT	Carbon Steel	ASTM A 105
11	Name plate	Stainless Steel	SS304
12	Name plate Rivet	Aluminum	

## How to Order

Example: 1No. DN15 FMBT50 Forbes Marshall Bucket trap with screwed BSPT connections, IBR

## Installation

The Trap must be installed with the body upright so that the bucket is rising and falling vertically. The inlet and outlet connections should be in a horizontal plane, with the trap installed below the drain point so that a water seal can be maintained around the open end of the bucket.

## Recommended Tightening Torques

Size (DN)	Seat (B)	Stud and Nuts (J)	Strainer Cap
15, 20	23-27 Nm	25-28 Nm	90-100 Nm
25	80-88 Nm	85-95 Nm	125-145 Nm

## Spare Parts

The spare parts available are shown in heavy outline. Parts drawn in broken line are not supplied as spares.

## Available Spares

Valve And Seat Assembly	A, B, C, D (2 Nos.)
Strainer Screen	F
Bucket	G
Cover Gasket	E
Set of cover Studs and Nuts	J

## How to Order Spares

Always order spares by using the description given in the column headed "Available Spares" and stating the size and series of the trap. For codes refer user manual.

Example :1 No. valve and seat assembly for DN15 Forbes Marshall Bucket Trap FMBT50

## How to Fit Valve and Seat Assembly

Isolate trap, remove cover by undoing cover nuts. Unhook the bucket from the valve lever **A**. Remove the valve seat **B**. Remove the valve guide plate **C**. by undoing the two screws **D**. Screw in new valve seat, using a little jointing paste on the threads and making sure the joint faces are clean. Fix new valve guide plate in position with new screws supplied, hook new valve lever over pins on valve guide plate and centralise valve to the orifice and tighten screws.

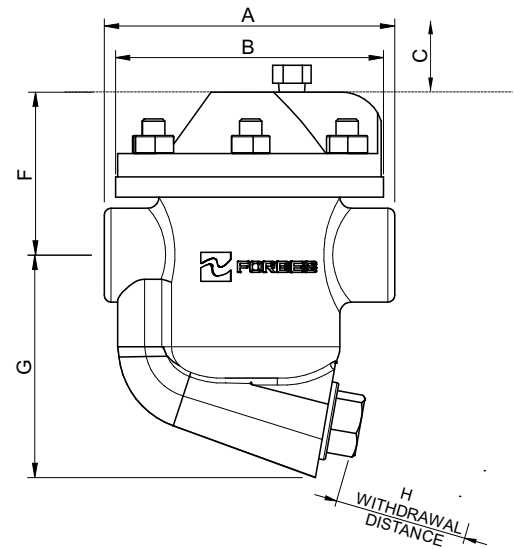

## Dimensions(approx.)in mm

Size(DN)	A	B	C	F	G	H	WT.(Kg)
15	130	120	110	75	100	65	5.50
20	130	120	150	93	117	65	6.25
25	180	165	170	132	127	85	2.25

GENTOL ± 3.0

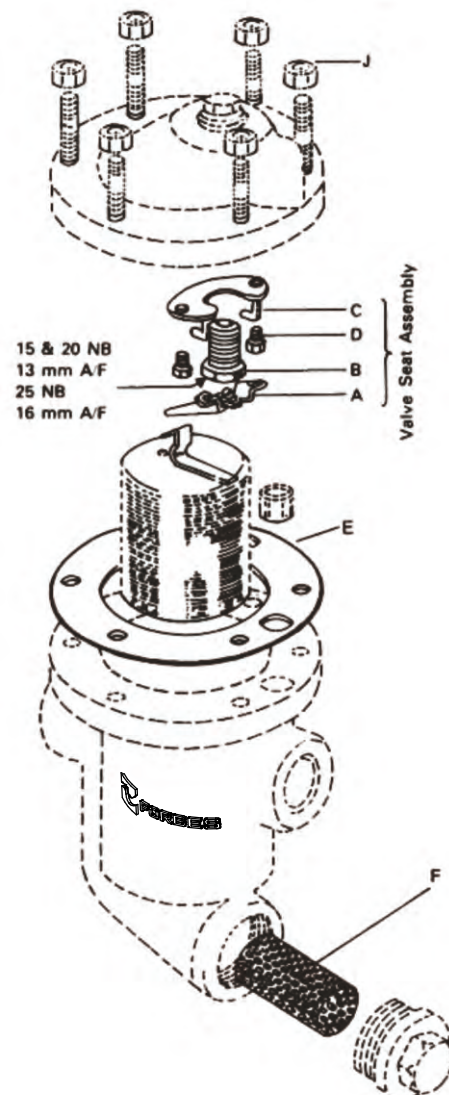

Capacity Chart (DN15)

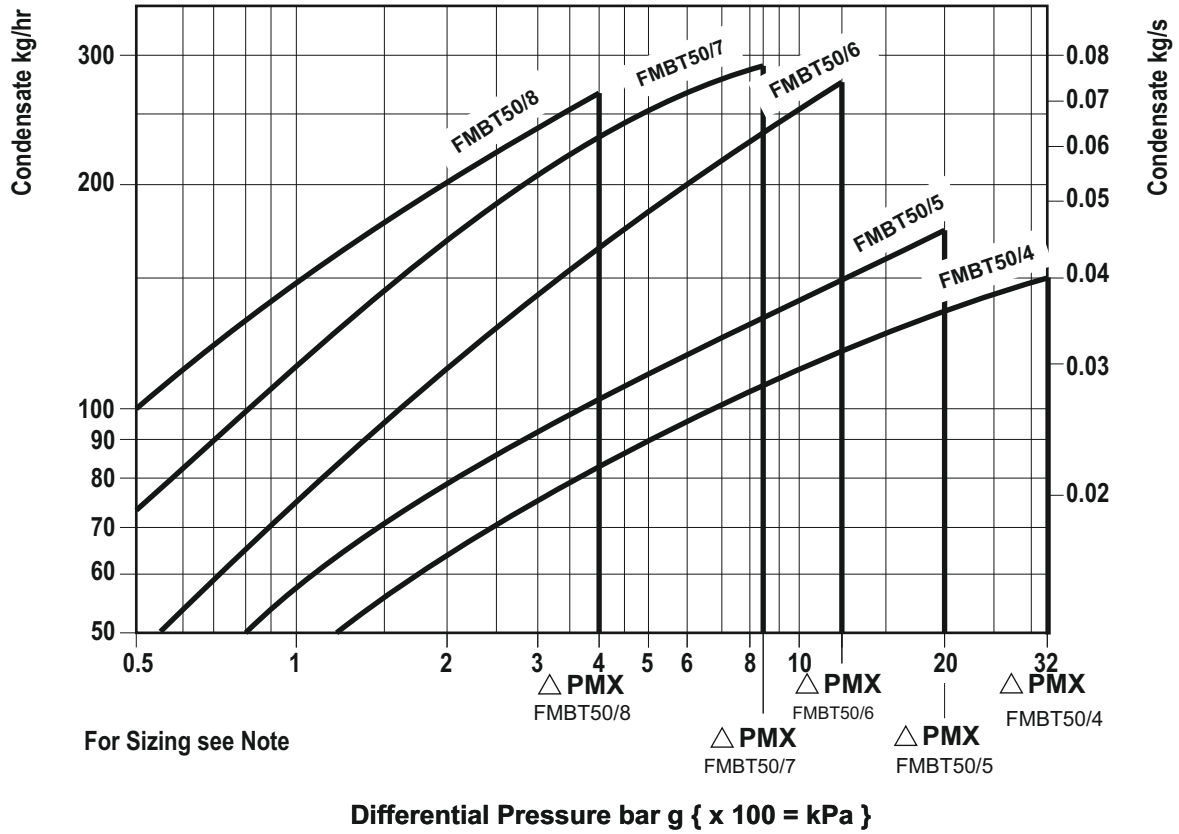

Capacity Chart (DN20)

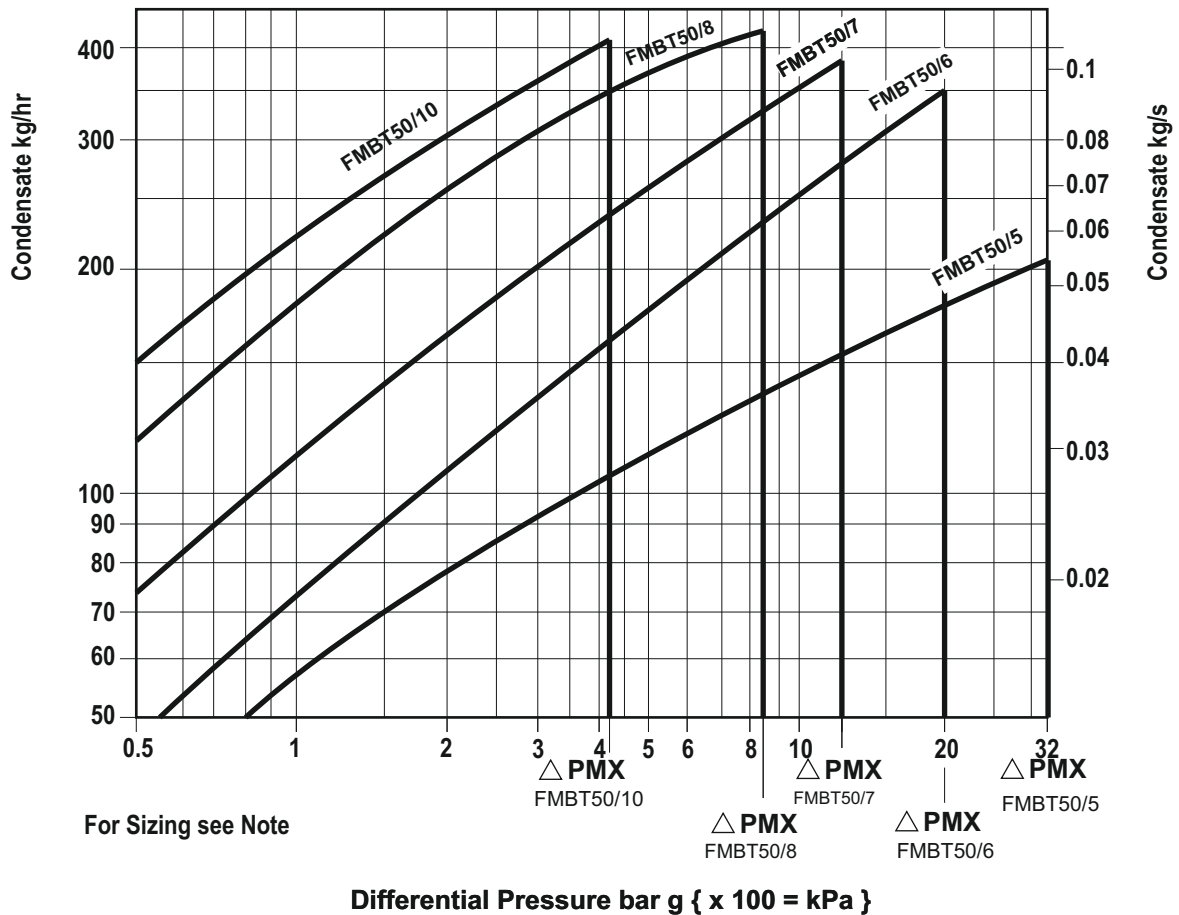

### Capacity Chart (DN25)

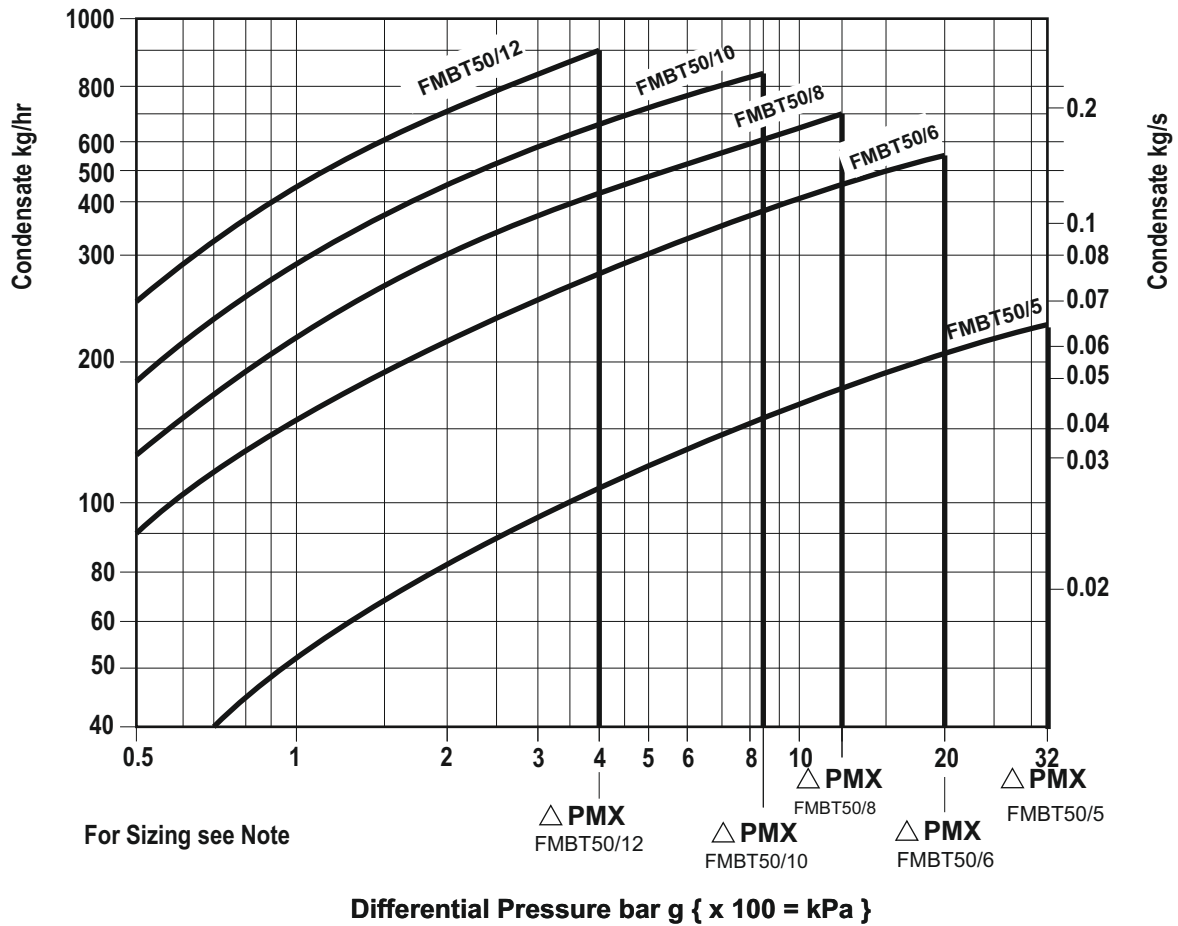

**Note :**

Trap should be selected for the most appropriate working differential pressure and not on the basis of load e.g. DN25 FMBT50, 80 Kg/h at 7 bar differential should be handled by FMBT50/10 and not FMBT50/5



www.forbesmarshall.com

Forbes Marshall Arca

Codel International

Krohne Marshall

Forbes Vyncke

Forbes Marshall Steam Systems

**A: Forbes Marshall Pvt. Ltd.**  
Opp. 106th Milestone, CTS 2220,  
Mumbai-Pune Road, Kasarwadi,  
Pune MH 411034 INDIA  
**P:** +91(0)20-68138555  
**F:** +91(0)20-68138402

**E:** ccmidc@forbesmarshall.com

© All rights reserved. Any reproduction or distribution in part or as a whole without written permission of Forbes Marshall Pvt Ltd, its associate companies or its subsidiaries ("FM Group") is prohibited. Information, designs or specifications in this document are subject to change without notice. Responsibility for suitability, selection, installation, use, operation or maintenance of the product(s) rests solely with the purchaser and/or user. The contents of this document are presented for informational purposes only. FM Group disclaims liabilities or losses that may be incurred as a consequence of the use of this information.

**Forbes Marshall International Pte. Ltd.**  
16A, Tuas Avenue 1,  
#05-21, JTC Space @Tuas  
Singapore - 639533  
**P:** +65 6219 3890

**CIN No:** U28996PN1985PTC037806